

R+L HYDRAULICS

HYDRAULIC COMPONENTS BY TIMKEN

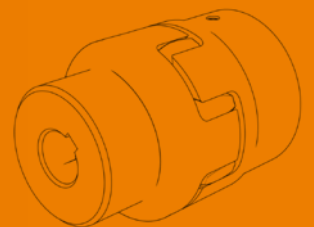

PUMPENTRÄGER UND ZUBEHÖR BELLHOUSINGS AND ACCESSORIES

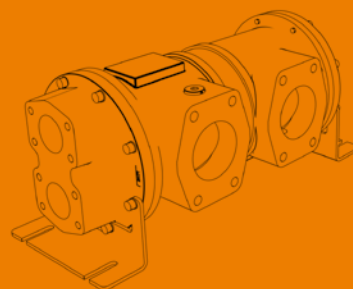
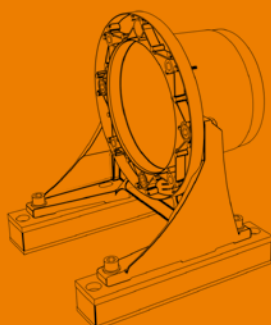
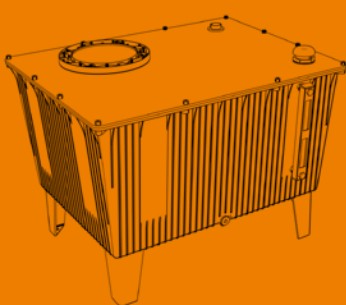

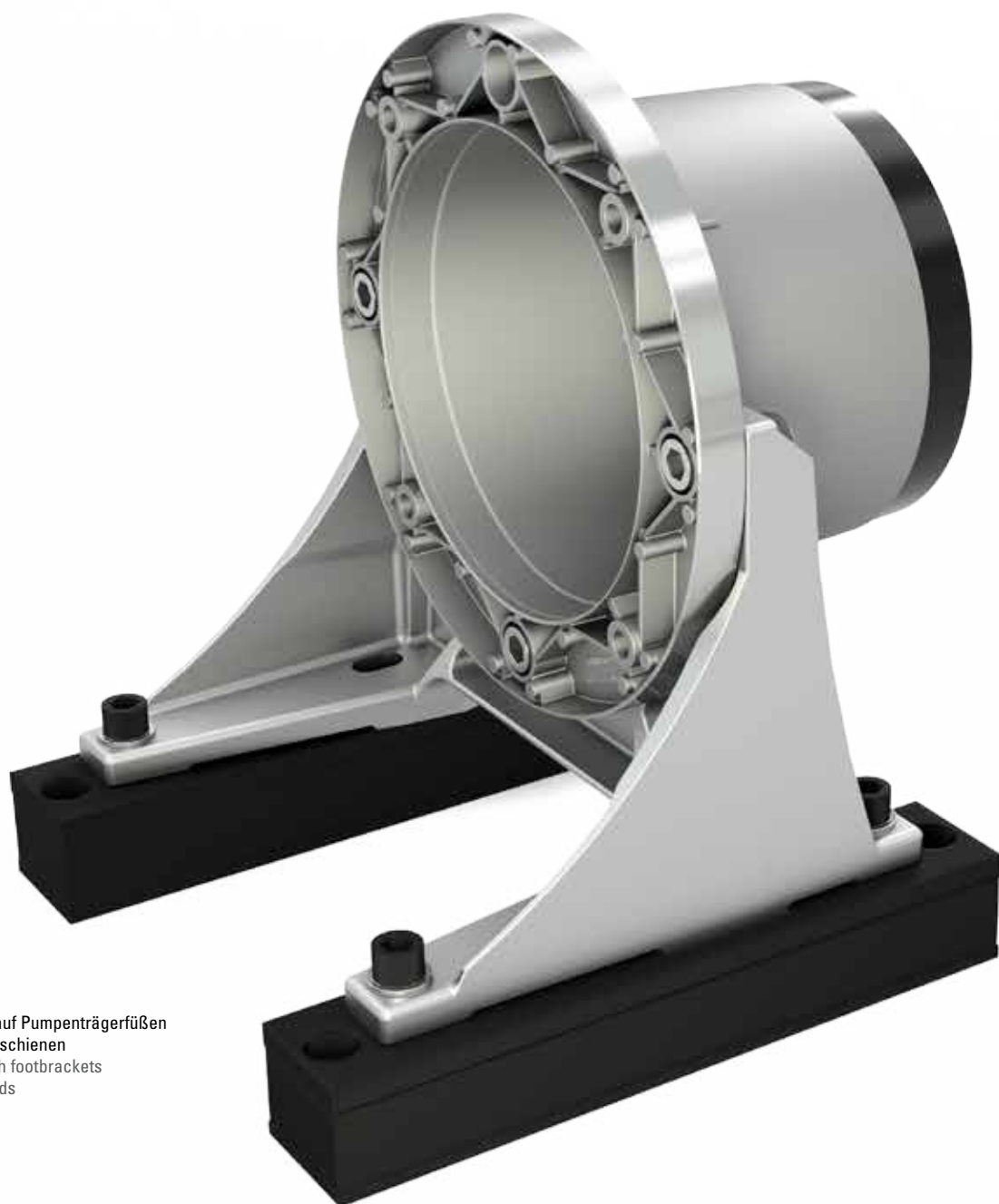

Pumpenträger auf Pumpenträgerfüßen
und Dämpfungsschienen
Bellhousing with footbrackets
and damping rods

PUMPENTRÄGER UND ZUBEHÖR BELLHOUSINGS AND ACCESSORIES

PUMPENTRÄGER NACH VDMA 24 561 BELLHOUSINGS ACC. TO VDMA 24 561	12
PUMPENTRÄGER AUS GRAUGUSS GG-25 BELLHOUSINGS MADE OF CAST IRON GG-25	17
PUMPENTRÄGER FÜR ZAHNRADPUMPEN BELLHOUSINGS FOR GEAR PUMPS	18
LECKÖL- UND MONTAGEBOHRUNGEN LEAKAGE- AND INSPECTION HOLES	22
MONTAGEPLATTEN UND PUMPENTRÄGERDICHTUNGEN MOUNTING PLATES AND BELLHOUSING GASKETS	23
KÜHLPUMPENTRÄGER SERIE KPV COOLER BELLHOUSINGS SERIES KPV	24
PUMPENTRÄGERFÜSSE FOOTBRACKETS	30
DÄMPFUNGSRINGE DAMPING RINGS	33
DÄMPFUNGSSCHIENEN DAMPING RODS	34

PUMPENTRÄGER NACH VDMA 24 561

BELLHOUSINGS ACC. TO VDMA 24 561

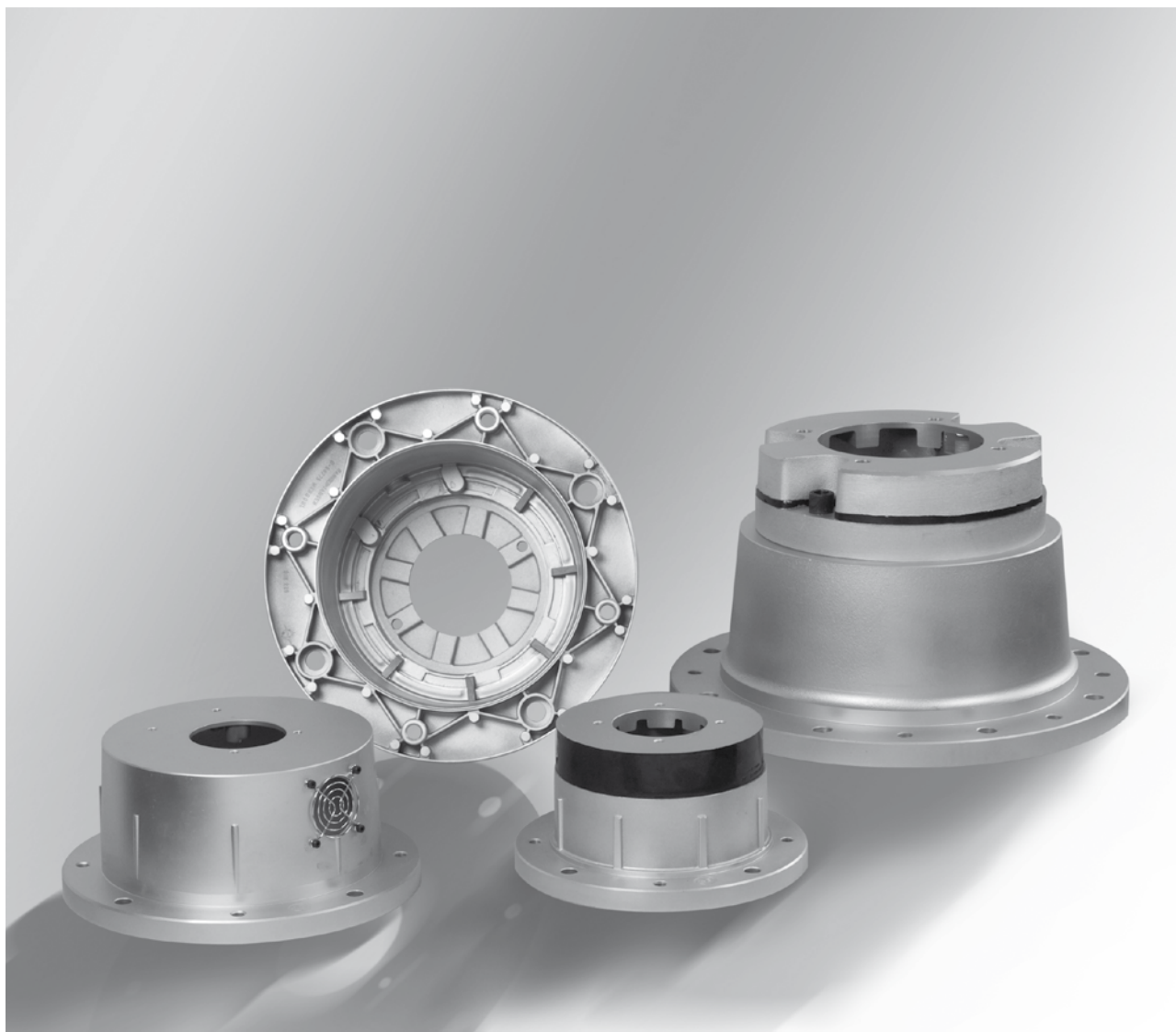

PRODUKTEIGENSCHAFTEN FEATURES

- Abmessungen gemäß VDMA 24 561
- Starre und gedämpfte Ausführung mit identischer Längenabstufung
- Problemloses Austauschen der Ausführungen untereinander möglich
- Dimensions acc. to VDMA 24 561
- Rigid and noise damping versions in identical length
- Easy interchangeability

TYPENBEZEICHNUNG

MODEL TYPE

RV 250 /

VDMA Pumpenträger VDMA bellhousing	
Flansch-Ø Flange dia.	160
	200
	250
	300
	350
	400
	450
	550
660	
800	

Totale Pumpenträgerlänge inkl. DF
Total length of bellhousing incl. DF

Siehe Tabellen Seite 15–17
See tables page 15–17

148 /

XXXX/

Pumpenanschluss Pump connection	
XXXX	Bearbeitungscode Internal machining code

DF/

Interner Zusatzcode für Optionen Optional internal code	
ZF	Zwischenflansch Pumpenseite Intermediate flange pump side
MZF	Zwischenflansch Motorseite Intermediate flange motor side
ZR	Zentrierring Pumpenseite Centering ring pump side
MB	Inspektionsöffnung Inspection hole
LB	Leckölbohrung Leakage bore
E	Einpressmutter Press nut
GI	Mit Schutzgitter für MB Including protective grid for MB
ST	Mit Stopfen für MB Including drain plug for MB

Gedämpfter Pumpenträger

Bellhousing with noise reduction

-	Ohne Dämpfungsflansch Without damping flange
DF	Mit integrierter Dämpfung von 250 – 350 (Monobloc) With integrated damping from 250 – 350 (Monobloc)
DF350	
DV400	Mit Dämpfungsflansch ab RV400 With damping flange up from RV400
DF401	

ZULÄSSIGE GEWICHTSBELASTUNG DER GEDÄMPFTEN PUMPENTRÄGER

PERMITTED WEIGHT LOAD OF DAMPED BELLHOUSINGS

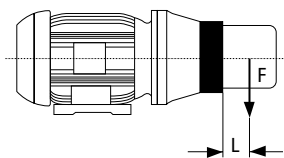

Zulässige Gewichtsbelastung der gedämpften Pumpenträger und Dämpfungsflanche unter Berücksichtigung einer Betriebstemperatur bis 60°C

Permitted weight load for dampened bellhousing and damping flange valid for an operating temperature of 60°C

	Pumpenträger gedämpft Bellhousing noise reduction			Dämpfungsflansch Damping flange	
	RV 250	RV 300	RV 350	DV 400	DF 401/1N
Schwerpunktstand L [mm] Centre to centre spacing [mm]	100	100	100	300	300
Zul. Gewichtskraft F [N] Permitted weight load F [N]	400	1300	1500	2500	2500

Für andere Schwerpunktabstände L_x errechnet sich die zulässige Gewichtskraft F_{Zul} aus der Näherungsformel:

Other centre to centre distances L_x, the permitted weight load F_{Zul} can be calculated acc. to the approximation formula:

$$F_{Zul} = F + 0.5 F \left(\frac{L}{L_x} - 1 \right)$$

Max. zulässige Betriebstemperatur +80 °C, kurzzeitig +100 °C
Max. permitted operating temperature +80 °C, for short periods +100 °C

MONOBLOC-PUMPENTRÄGER, GEDÄMPFT NACH VDMA 24 561

MONOBLOC-BELLHOUSINGS WITH NOISE DAMPER ACC. TO VDMA 24 561

Hersteller von Hydraulik-Zubehör haben bekanntlich keinen Einfluss auf den Geräuschcharakter einer Pumpe. Die Beeinflussung von Luftschall und Flüssigkeitsschall und auch des Körperschalls einer Pumpe obliegt dem Pumpenkonstrukteur.

Der Geräuschcharakter einer Pumpe – bestehend aus Grundfrequenz und Oberwellen – kann besonders unangenehm werden, wenn sich der Körperschall in andere Bauelemente eines Hydraulikaggregates und hiermit verbundene Maschinenelemente fortpflanzt. Die Volumenpulsation und somit Druckpulsation einer Pumpe kann zu besonders unangenehmen Strukturresonanzen führen, welche teilweise selbst durch eine Schalldruckpegelmessung in Form des dB(A)-Wertes nicht immer umfassend zum Ausdruck kommen.

Zur Vermeidung der Fortpflanzung dieser Pulsation in andere Bauelemente ist eine weitestgehende Körperschalltrennung zu erwirken. Neben der erforderlichen Verwendung einer drehelastischen Kupplung – wie der SPIDEX®-Kupplung – und von Druckschläuchen anstelle von Verrohrungen, geschieht die wesentliche Körperschalltrennung mittels eines gedämpften Pumpenträgers. Derartige Dämpfungsflansche enthalten ein Elastomer, welches den metallischen Kontakt zwischen Pumpe und den übrigen Elementen eines Hydraulikaggregates verhindert.

Die Firma R+L HYDRAULICS fertigt und vertreibt Dämpfungsflansche zur Geräuschreduzierung von Hydraulikaggregaten. Aufgrund der langjährigen Erfahrung hat R+L HYDRAULICS ein gedämpftes Monobloc-Pumpenträgersystem (Abb. 4) entwickelt, welches eine wesentliche Vereinfachung gegenüber der üblichen Bauweise bietet. Die Verbindung zwischen Dämpfungsring und Pumpenträger erfolgt jetzt gänzlich ohne Verschraubungen. Vielmehr wird der Pumpenflansch direkt durch eine formschlüssige, anvulkanisierte Elastomer-Verbindung (sowohl in Drehrichtung als auch als Radialabstützung) unmittelbar mit dem eigentlichen Pumpenträger verbunden.



Abb. 1 Schalldruckpegelmessung Flügelzellenpumpe
Fig. 1 Sound-pressure level monitoring vane pump

Das Ergebnis ist eine deutlich verbesserte Steifigkeit in Verbindung mit hervorragenden Dämpfungseigenschaften. Bei einem Monobloc-Pumpenträger mit Motorflanschdurchmesser 300 mm, passend zu einem E-Motor, Baugröße 132, ergibt sich beispielsweise eine Zerreißkraft von 56 kN. Die höhere Steifigkeit bewirkt vor allem geringere Verlagerungswerte und somit eine höhere Lebensdauer der Kupplung.

Der Dämpfungseffekt des Monobloc-Pumpenträgers ist nicht nur abhängig von dem speziellen Einsatzfall, sondern auch von dem Geräuschcharakter der Pumpe. Je unangenehmer das Pumpengeräusch, desto höher der Dämpfungsgrad. Das Spektrum der Schallpegelreduzierung liegt in der Regel zwischen 3 dB(A) bei geräuscharmeren Pumpen (Abb. 1) und über 10 dB(A) bei Pumpen (Abb. 2), welche ein unangenehmeres „Geräuscherlebnis“ vermitteln.

It is a well-known fact, that manufacturers of hydraulic accessories have no influence at all upon the noise characteristics of a pump. The influence of air sound and liquid sound, but also that of structure-borne noise is incumbent on the pump design engineer himself.

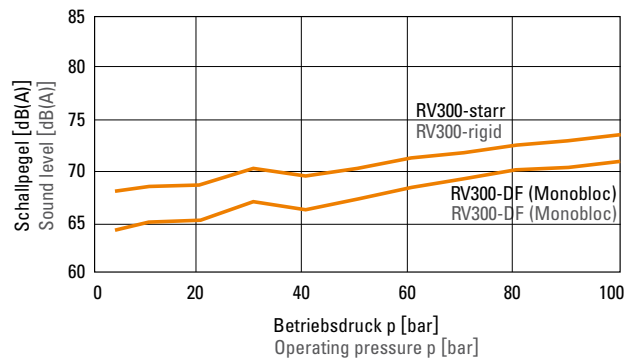
The noise characteristics of a pump – consisting of basic frequency and harmonic waves – can become very annoying, when the structure-borne noise of the hydraulic unit and that of the herewith integrated elements of the machine are propagated. The volume vibration of a pump, and with it the pressure vibration, can cause a particularly unpleasant resonance of the structure, which itself cannot always be expressed, even by means of a sound-pressure level monitoring in form of a dB(A)-value.

In order to prevent the propagation of this vibration into other integrated elements as far as possible, the separation of the structure-borne noises is to be achieved. And, apart from having to use a flexible coupling – like a SPIDEX® coupling – and pressure piping instead of the conventional one, the structure-borne noises will be essentially separated through the implementation of bell-housings with noise damper. Damper flanges of this type contain an elastomer, which hinders the metallic contact between the pump and the other elements of the hydraulic unit.

The company R+L HYDRAULICS manufactures and distributes damper flanges for the noise reduction of hydraulic units. On account of its many years of experience in this field, R+L HYDRAULICS has developed a monobloc bellhousing system with noise damping (Fig. 4), which offers an essential simplification towards the conventional construction. The connection between the noise damper ring and the bellhousing is now totally made without bolting. Rather more, the pump flange is directly combined with the bellhousing by means of a form-conclusive and vulcanised elastomer compound (as well in the sense of rotation as in the radial back-up).



Abb. 2 Schalldruckpegelmessung Außenzahnradpumpe
Fig. 2 Sound-pressure level monitoring external gear pump

The result is a significant improvement of the stiffness, in combination with first rate noise damping characteristics i.e. meaning a tensile strength of 56 kN, in the case of a monobloc-bellhousing with a motor flange diameter of 300 mm, suitable for an E-motor frame size 132. The higher stiffness results especially in lesser misalignments, which go together with a higher service life of the coupling.

The noise damping effect of the monobloc-bellhousing does not only depend on the special field case but also on the noise characteristics of the pump. The more annoying the pump's noise is, the higher the damping degree will be. The spectrum of soundlevel reduction generally lies between 3 dB(A) in the case of less noisy pumps (Fig. 1) and more than 10 dB(A) by pumps (Fig. 2), which procure a more annoying "noise-experience".

STARRE AUSFÜHRUNG RV
RIGID VERSION RV

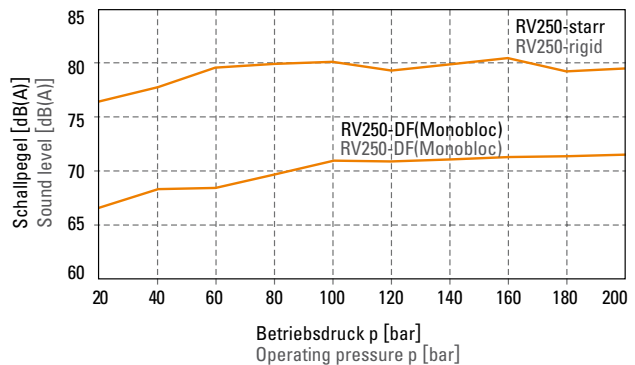
Ø D1 = 160 – 350 mm
Ø D1 = 160 – 350 mm



Abb. 3 Pumpenträger, starr, nach VDMA 24 561
Fig. 3 Bell housings, rigid, acc. to VDMA 24 561

MONOBLOC-SYSTEM, GEDÄMPFTE AUSFÜHRUNG
MONOBLOC-SYSTEM, NOISE REDUCTION VERSION

Ø D1 = 250 – 350 mm
Ø D1 = 250 – 350 mm



Abb. 4 Monobloc-Pumpenträger, gedämpft, nach VDMA 24 561
Formschlüssige Verbindung ohne Verschraubung
Fig. 4 Monobloc-Bell housings with noise damper, acc. to VDMA 24 561
Form fitting without screw joint

RV.../.../...

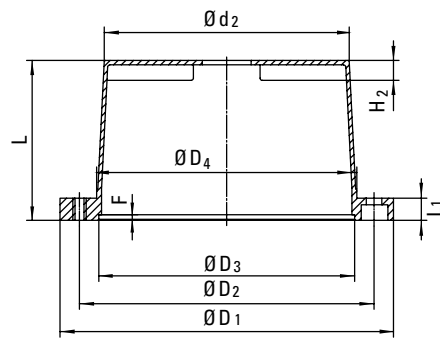

RV.../.../.../DF

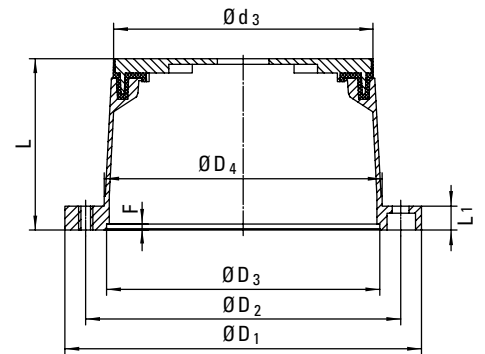
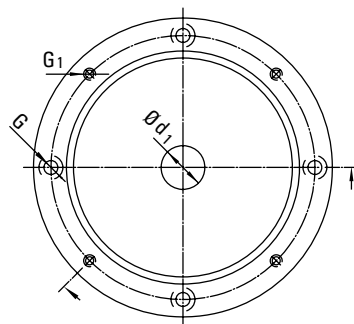

Pumpen- trägartyp Type of bellhousing	E-Motor Baugröße Frame size	Leistung Power [kW]	Wellenende Shaftend D x l [mm]	Fußflansch Footbracket	Abmessungen Dimensions												
					D1 [mm]	D2 [mm]	D3 [mm]	D4 [mm]	d1 [mm]	d2 [mm]	d3 [mm]	L [mm]	L1 [mm]	F [mm]	G [mm]	G1	H2 [mm]
RV 160/80/...	71	0.25	14 x 30	PTFL160	160	130	110	110	21	107	-	80	13	4	9	M8	8.5
RV 160/90/...		90															
RV 200/100/...	80	0.55 – 0.75	19 x 40	PTFL200	200	165	130	145	36	129	-	100	16	5	11	M10	12.5
RV 200/110/...												110					
RV 200/118/...	90 S+L	1.1 – 1.5	24 x 50	PTFL200	200	165	130	145	36	128	-	118	19	5	14	M12	14.5
RV 200/124/...												124					
RV 200/140/...												140					
RV 250/120/...												120					
RV 250/124/...	112 M	2.2 – 3.0	28 x 60	PTFS250	250	215	180	190	45	178	172	124	19	5	14	M12	14.5
RV 250/128/...												128					
RV 250/135/...												135					
RV 250/148/...												148					
RV 250/175/...												175					
RV 300/144/...												144					
RV 300/150/...	132 S	5.5	38 x 80	PTFL300 PTFS300	300	265	230	234	50	222	217	150	20	5	14	M12	18.0
RV 300/155/...												155					
RV 300/168/...												168					
RV 300/196/...												196					
RV 350/188/...												188					
RV 350/204/...	180 M+L	11.0 – 15.0	42 x 110	PTFS350	350	300	250	260	41	236	231	204	26	6	18	M16	18.0
RV 350/204/...												204					
RV 350/228/...												228					
RV 350/256/...												256					

Pumpenträger mit Flansch-Ø D1 = 160 mm nach VDMA 24 561 nur in starrer Ausführung. Ausführung mit Flansch-Ø D1 = 200 mm mit verschraubtem Dämpfungsflansch auf Anfrage.
Bell housings with flange-Ø D1 = 160 mm acc. to VDMA 24 561 only in rigid version. Noise reduction version with flange-Ø D1 = 200 mm with screwed damping flange on request.

STARRE AUSFÜHRUNG RV RIGID VERSION RV

Ø D1 = 400 – 800 mm
Ø D1 = 400 – 800 mm

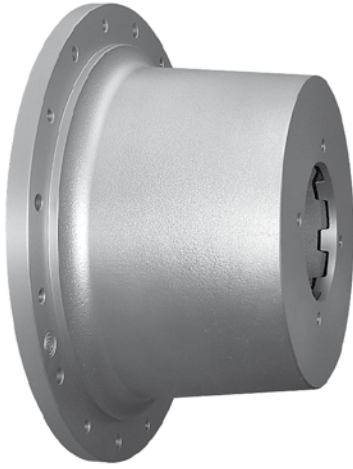

GEDÄMPFTE AUSFÜHRUNG, 2-TEILIG NOISE REDUCTION VERSION, 2-PIECE

Ø D1 = 400 – 800 mm
Ø D1 = 400 – 800 mm

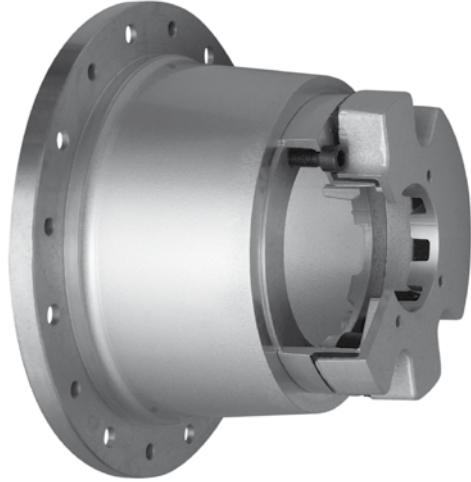

RV.../.../...

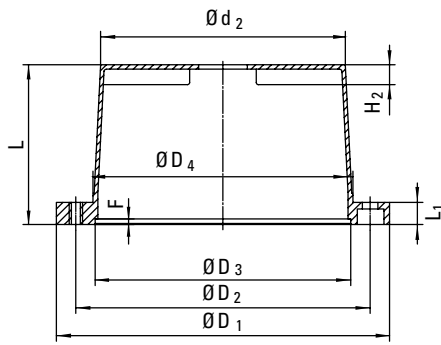

Ab Größe 450, 8 Bohrungen
From Size 450, 8 bores

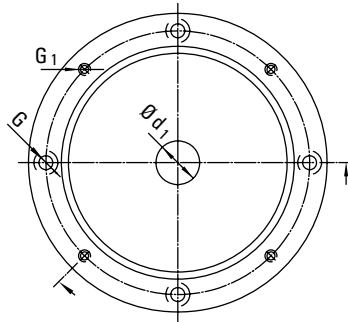

RV.../.../DF350
RV.../.../DF401

RV.../.../DV400

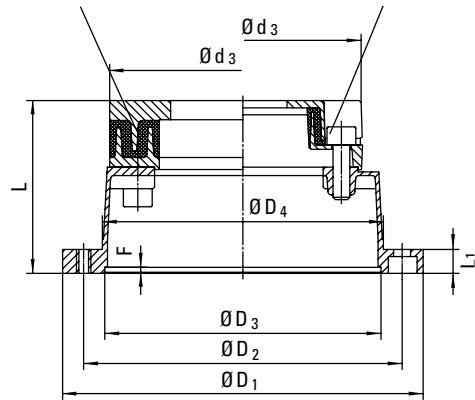

Pumpen- trägartyp Type of bellhousing	E-Motor Baugröße Frame size	Leistung Power [kW]	Wellenende Shaftend D x l [mm]	Fußflansch Footbracket	Abmessungen Dimensions																												
					D1 [mm]	D2 [mm]	D3 [mm]	D4 [mm]	d1 min [mm]	d1 min [mm]	d2 [mm]	d3 [mm]	L [mm]	L1 [mm]	F [mm]	G [mm]	G1 [mm]	H2 [mm]															
RV 400/204/...	200 L	30	55 x 110	PTFS400	400	350	300	300	50		265	260	204	26	6	18	M16	22															
RV 400/228/...											262		228																				
RV 400/256/...											259		256																				
RV 450/234/...	225 S	37	60 x 140	PTFS450	450	400	350	350	80		301	260	234	26	6	18	M16	20															
RV 450/262/...	225 M	45									297		262																				
RV 450/285/...											285		285																				
RV 450/315/...	250 M	55	65 x 140	PTS5500	550	500	450	450	80	50 (DF350)	276	283 (DV400)	315	26	6	18	M16	20															
RV 550/248/...											280 S+M		75-90						75 x 140	PTS5500	550	500	450	450	80	362	283 (DV400)	248	26	6	18	M16	20
RV 550/265/...																										360		265					
RV 550/275/...	315 S+M+L	110-132	80 x 170	PTS660	660	600	550	550	80	50 (DV400)	358	283 (DV400)	275	26	6	18	M16	20															
RV 550/295/...											354		295																				
RV 550/315/...											351		315																				
RV 660/310/...	355 L	250-315	95 x 170	—	800	740	680	680	125	80 (DF401)	414	362 (DF401)	310	32	8	23	M20	20															
RV 660/330/...											409		330																				
RV 660/345/...											408		345																				
RV 800/315/...**	400 L	355-400	100 x 210	—	800	740	680	680	125		468		315	60	10	23	M20	35															
RV 800/335/...**											474		335																				
RV 800/350/...**											485		350																				
RV 800/443/...**											490		443																				

**Nicht in der VDMA-Norm enthalten **Not included in the VDMA-Standard

Andere Dämpfungskombinationen und separate Dämpfungsflansche auf Anfrage
Other damping combinations and separate damping flanges on request

PUMPENTRÄGER AUS GRAUGUSS GG-25 BELLOUSINGS MADE OF CAST IRON GG-25

Pumpenträger aus Grauguss sind speziell für folgende Anwendungen entwickelt worden:

- Hohe Belastungen
- Mobilhydraulik
- Bergbau, Offshore
- Servomotorische Antriebe

Aufgrund der hohen Masse gute Geräuschdämpfungseigenschaften.

Starre Ausführung GG-RV

Werkstoff: EN-GJL-250
 Ø D1 = 250 – 660 mm
 Ab Lager verfügbar
 Andere Größen auf Anfrage
 Montageanleitung beachten

Bellousings made of cast iron are especially developed for the following applications:

- High loads
- Mobile hydraulic
- Mining, Offshore
- Servomotorical drives

Based on the high weight, good noise reduction performance.

Rigid version GG-RV

Material: EN-GJL-250
 Ø D1 = 250 – 660 mm
 Available from stock
 Other sizes on request
 Consider operation manual

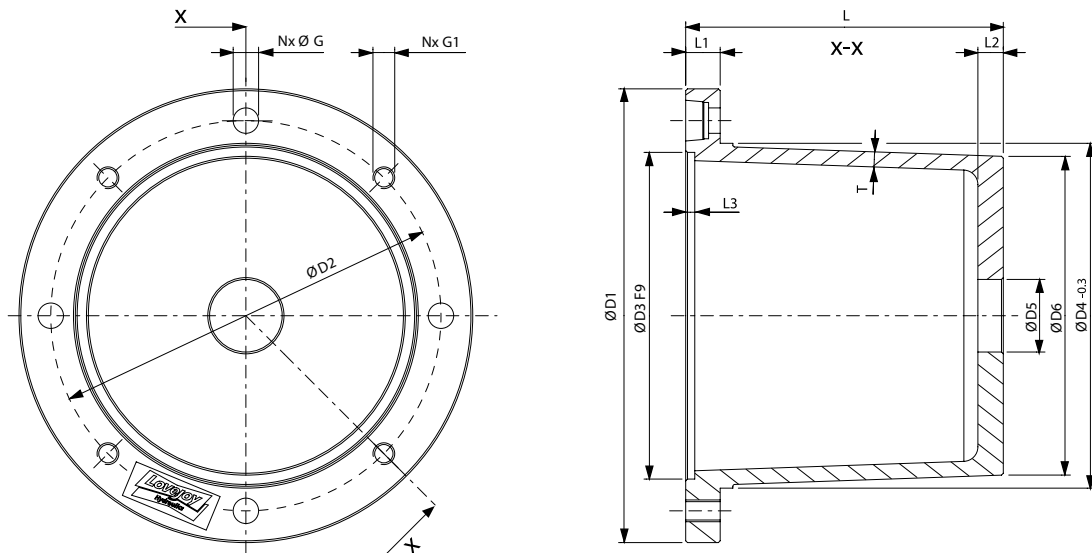

PUMPENTRÄGER GG-PT BELLOUSINGS GG-PT

Pumpenträgertyp Type of bellhousing	E-Motor Baugröße Frame size	Leistung Power [kW]	Wellenende Shaft end D x l [mm]	Fußflanschtyp Type of foot bracket	Abmessungen Dimensions [mm]													Gewicht Weight [kg]	
					D1	D2	D3	D4	D5	D6	T	L	L1	L2	L3	N	G		G1
GG-RV250/175/...	112 M	4.0	28 x 60	GG-PTFS 250	250	215	180	190	40	176	10	175	19	14	5	4	14	M12	10.50
GG-RV300/144/...	132 S	5.5	38 x 80	GG-PTFS 300	300	265	230	234	50	222	10	144	20	16	5	4	14	M12	13.00
GG-RV300/196/...	132 M	7.5							75	218		196							15.00
GG-RV350/188/...	160 M+L	11.0 + 15.0	42 x 110	GG-PTFS 350	350	300	250	260	40	245	10	188	26	18	6	4	18	M16	20.50
GG-RV350/204/...									50	244		204							21.00
GG-RV350/228/...	180 M+L	18.5 + 22.0	48 x 110	GG-PTFS 350	350	300	250	260	65	243	10	228	26	18	6	4	18	M16	22.00
GG-RV350/256/...									85	241		256							23.50
GG-RV400/204/...	200 L	30.0	55 x 110	GG-PTFS 400	400	350	300	300	45	284	10	204	26	20	6	4	18	M16	28.00
GG-RV400/228/...									80	283		228							28.50
GG-RV450/234/...	225 S	37.0	60 x 140	GG-PTFS 450	450	400	350	350	50	332	10	234	26	20	6	8	18	M16	36.00
GG-RV450/262/...	225 M	45.0							80	330		262							37.50
GG-RV550/248/...	250 M	55.0	65 x 140	GG-PTFS 550	550	500	450	450	80	431	10	248	26	20	6	8	18	M16	53.00
GG-RV550/265/...	280 S+M	75.0 + 90.0	75 x 140						80	430		265							53.50
GG-RV660/330/...	315 S+M+L	160.0 + 200.0	80 x 170	GG-PTFS 660	660	600	550	550	80	526	10	330	32	24	6	8	23	M20	86.00

Leckage- bzw. Montagebohrungen sind bei der Bestellung anzugeben.
 Leckage- or inspection holes respectively have to be specified with the order.

PUMPENTRÄGER BELLOUSINGS

PUMPENTRÄGER FÜR ZAHNRADPUMPEN

BELLHOUSINGS FOR GEAR PUMPS

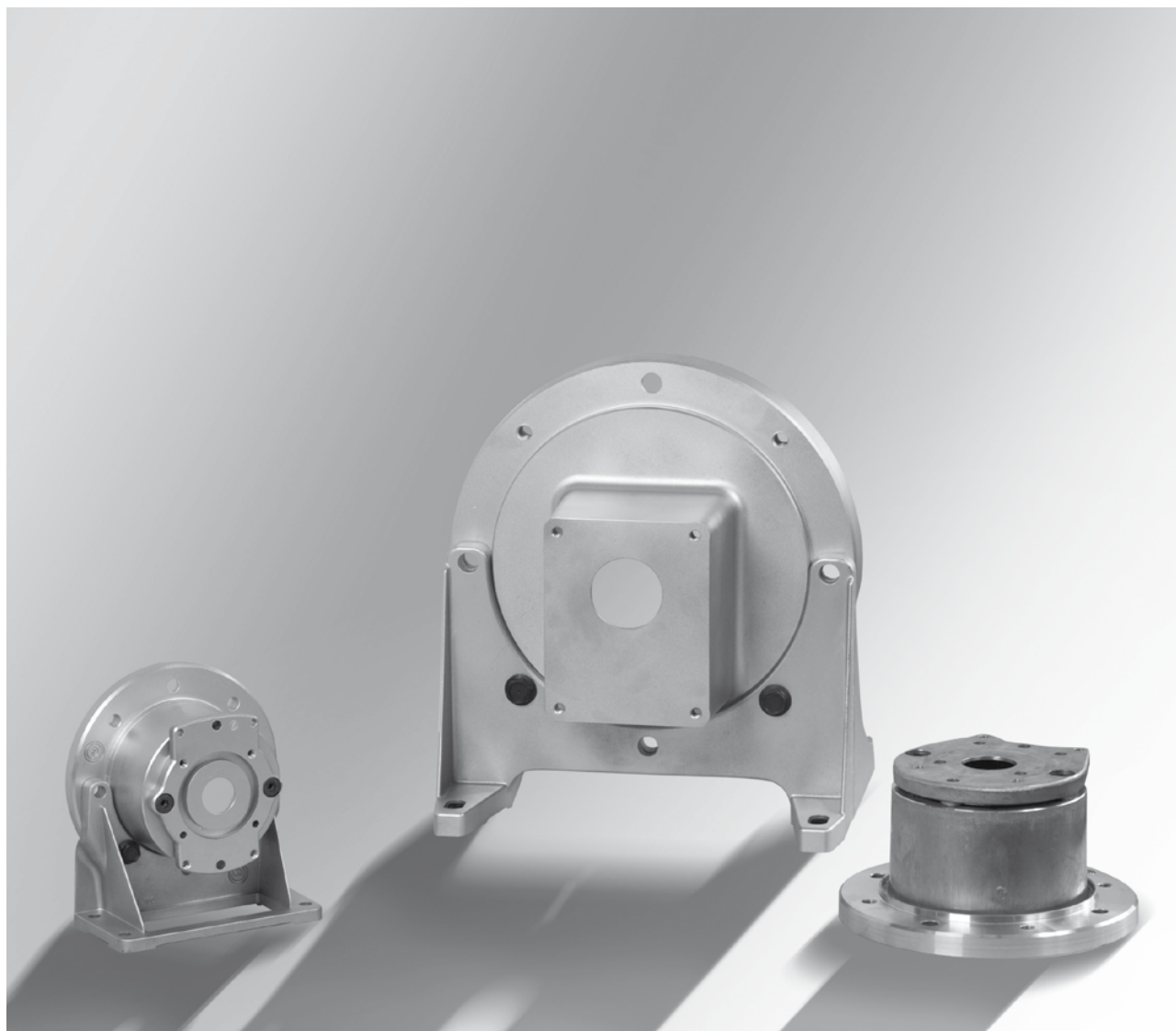

PRODUKTEIGENSCHAFTEN

FEATURES

- Motorbundhöhe gemäß VDMA 24 561
- Kombinierbar mit Fußflanschen nach VDMA 24 561
- Motorflanshdurchmesser von 160 – 400 mm
- Height of motor flange acc. to VDMA 24 561
- Optional combination with footbrackets acc. to VDMA 24 561
- Motor flange diameter from 160 – 400 mm

TYPENBEZEICHNUNG

MODEL TYPE

RV 250 /		110 /	XXXX /	B14 /	ZFV														
Pumpenträger Bellhousing		Pumpenträgerlänge Length of bellhousing		Motorbaufom Frame size															
Flansch-Ø Flange-Ø	160	Siehe Tabellen See tables		-	IM B 35														
	200			B 14	IM B 14														
	250	<table border="1"> <tr> <th colspan="2">Interner Zusatzcode für Optionen Optional internal code</th> </tr> <tr> <td>ZF</td> <td>Zwischenflansch Pumpenseite Intermediate flange pump side</td> </tr> <tr> <td>MZF</td> <td>Zwischenflansch Motorseite Intermediate flange motor side</td> </tr> <tr> <td>ZR</td> <td>Zentrierring Centering ring</td> </tr> <tr> <td>MB</td> <td>Inspektionsöffnung Inspection hole</td> </tr> <tr> <td>LB</td> <td>Leckölbohrung Leakage bore</td> </tr> <tr> <td>E</td> <td>Einpressmutter Press nut</td> </tr> </table>				Interner Zusatzcode für Optionen Optional internal code		ZF	Zwischenflansch Pumpenseite Intermediate flange pump side	MZF	Zwischenflansch Motorseite Intermediate flange motor side	ZR	Zentrierring Centering ring	MB	Inspektionsöffnung Inspection hole	LB	Leckölbohrung Leakage bore	E	Einpressmutter Press nut
	Interner Zusatzcode für Optionen Optional internal code																		
	ZF					Zwischenflansch Pumpenseite Intermediate flange pump side													
MZF	Zwischenflansch Motorseite Intermediate flange motor side																		
ZR	Zentrierring Centering ring																		
MB	Inspektionsöffnung Inspection hole																		
LB	Leckölbohrung Leakage bore																		
E	Einpressmutter Press nut																		
300	<table border="1"> <tr> <td colspan="2">Pumpenanschluss Pump connection</td> </tr> <tr> <td>XXXX</td> <td>Interner Bearbeitungscode Internal machining code</td> </tr> </table>				Pumpenanschluss Pump connection		XXXX	Interner Bearbeitungscode Internal machining code											
Pumpenanschluss Pump connection																			
XXXX	Interner Bearbeitungscode Internal machining code																		
350																			
400																			

PUMPENTRÄGER BELLOUSINGS

TYPENBEZEICHNUNG

MODEL TYPE

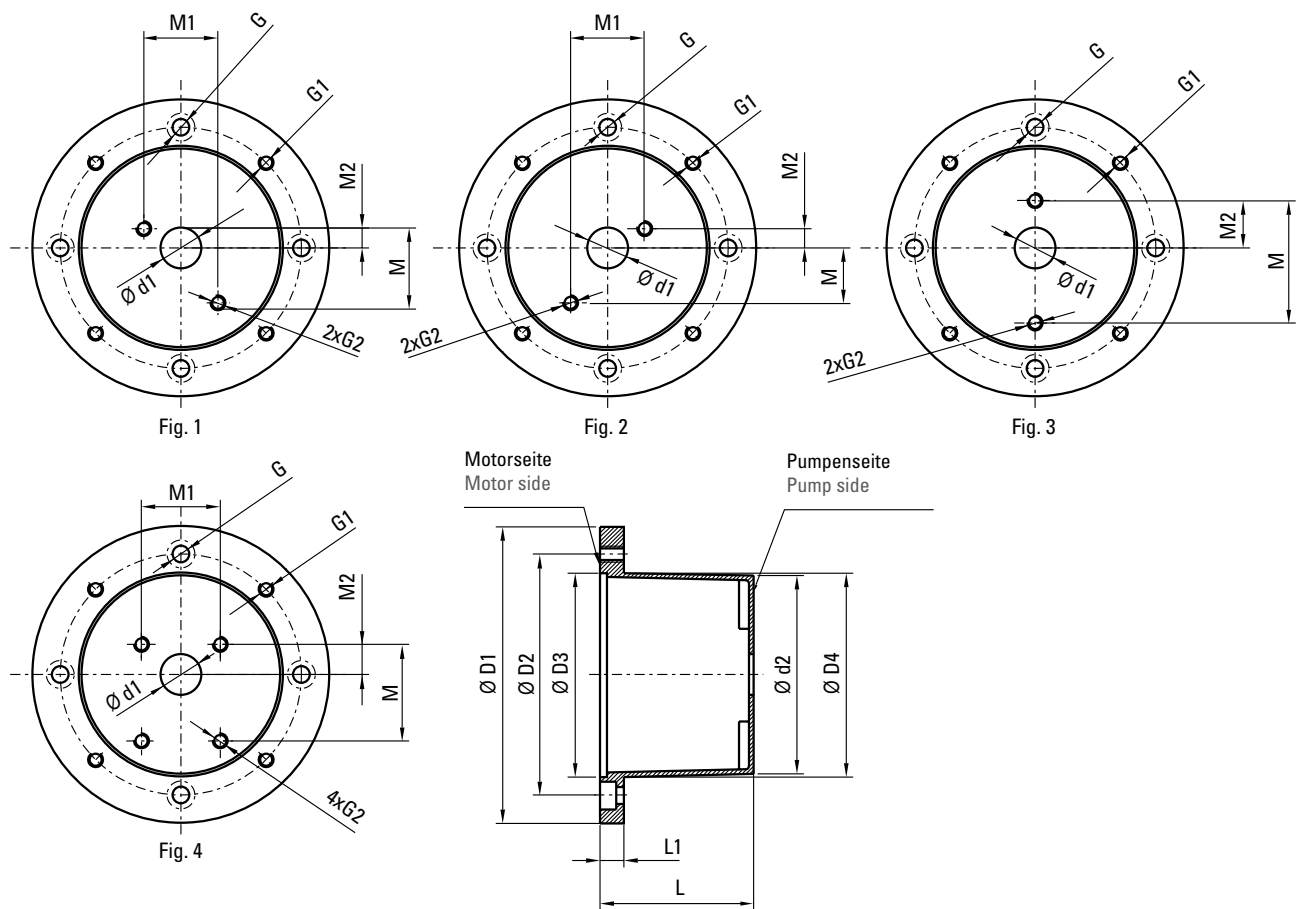

PUMPENTRÄGER FÜR ZAHNRADPUMPEN

BELLOUSINGS FOR GEAR PUMPS

Motorflansch – Ø 160 mm Motor flange – Ø 160 mm

Abmessungen Dimensions [mm]

Typ Type	Bohrbild Pump con.	D1	D2	D3	D4	d1	d2	L	L1	F	G	G1	G2	M	M1	M2					
RV160/70/401	Fig. 1	160	130	110	110	32.0	107	70	13	4	9	M8	2 x M8	40.0	40.0	10.35					
RV160/70/468	Fig. 3					22.0							2 x M6	66.0	25.5	33.00					
RV160/80/401	Fig. 1					32.0	Ø9	2 x M8				40.0	40.0	10.35							
RV160/80/401/B14						32.0															
RV160/80/448/ZFV*	Fig. 4					25.4	Ø9	4 x M6				72.0	52.4	26.20							
RV160/80/448/B14/ZFV*						30.0									73.0	56.0	24.50				
RV160/80/453/B14/ZFV*						30.0															
RV160/90/401	Fig. 1					32.0	M8	2 x M8				40.0	40.0	10.35							
RV160/90/401/B14						32.0															
RV160/90/448/ZFV*	Fig. 4					25.4	Ø9	4 x M6				72.0	52.4	26.20							
RV160/90/448/B14/ZFV*						25.4									73.0	56.0	24.50				
RV160/90/453/B14/ZFV*						30.0															
RV160/95/441/B14/ZFV*						80.0									4 x M8	100.0	72.0	34.50			
RV160/95/446/B14/ZFV*						36.5													100.0	72.0	34.50
RV160/105/446/B14/ZFV*						80.0															
RV160/110/441/B14/ZFV*						25.4													72.0	52.4	26.20
RV160/110/446/B14/ZFV*						80.0									100.0	72.0	34.50				
						36.5												96.2	71.5	32.70	

Motorflansch – Ø 200 mm Motor flange – Ø 200 mm

Abmessungen Dimensions [mm]

Typ Type	Bohrbild Pump con.	D1	D2	D3	D4	d1	d2	L	L1	F	G	G1	G2	M	M1	M2	
RV200/80/401	Fig. 1	200	165	130	145	32.00	129	80	16	5	11	M10	2 x M8	40.0	40.0	10.35	
RV200/80/448	Fig. 4					25.40							4 x M6	72.0	52.4	26.20	
RV200/80/453	Fig. 3					30.00							2 x M6	66.0	25.5	33.00	
RV200/80/468						22.00											
RV200/80/493	Fig. 4					33.00							4 x M6	72.0	52.4	26.20	
RV200/90/401	Fig. 1					32.00							2 x M8	40.0	40.0	10.35	
RV200/90/448	Fig. 4					25.40											4 x M6
RV200/90/453	Fig. 4					30.00							73.0	56.0	24.50		
RV200/90/468	Fig. 3					22.00										2 x M6	66.0
RV200/90/493	Fig. 4					33.00							4 x M6	72.0	52.4		
RV200/96/439/ZFV*						50.00										2 x M10	60.0
RV200/96/441/ZFV*						80.00							4 x M8	100.0	72.0		
RV200/96/446/ZFV*						36.50										96.2	71.5
RV200/96/459/ZFV*						36.50							62.0	62.0	23.30		
RV200/100/404						Fig. 4										52.00	2 x M8
RV200/100/405													63.00				
RV200/100/474													32.00	2 x M10	60.0	60.0	14.50
RV200/100/476													45.24				
RV200/106/439/ZFV*													50.00	4 x M8	100.0	72.0	34.50
RV200/106/441/ZFV*	80.00																
RV200/106/446/ZFV*	36.50	4 x M6	96.2	71.5	32.70												
RV200/106/459/ZFV*	36.50																
RV200/110/404	Fig. 4	52.00	2 x M8	62.0	62.0	23.30											
RV200/110/405		63.00															

Motorflansch – Ø 250 mm Motor flange – Ø 250 mm

Abmessungen Dimensions [mm]

Typ Type	Bohrbild Pump con.	D1	D2	D3	D4	d1	d2	L	L1	F	G	G1	G2	M	M1	M2	
RV250/110/401	Fig. 1	250	215	180	190	32.0	179	110	19	5	14	M12	2 x M8	40.0	40.0	10.35	
RV250/110/402						50.0							2 x M10	60.0	60.0	14.50	
RV250/110/439	Fig. 4					80.0							4 x M8	100.0	72.0	34.50	
RV250/110/446						36.5											72.0
RV250/110/448						25.4							4 x M6	73.0	56.0	24.50	
RV250/110/453						30.0											96.2
RV250/110/459						36.5							4 x M6	72.0	52.4	26.20	
RV250/110/462						33.0											4 x M8
RV250/110/493						77.0							4 x M6	72.0	52.4	26.20	
RV250/110/828						32.0											4 x M8
RV250/116/401						Fig. 1							50.0	2 x M8	40.0	40.0	
RV250/116/402													80.0				2 x M10
RV250/116/439	Fig. 4					36.5							4 x M8	100.0	72.0	34.50	
RV250/116/446						25.4											96.2
RV250/116/448						30.0							4 x M6	73.0	56.0	24.50	
RV250/116/453						36.5											96.2
RV250/116/459						33.0							4 x M6	72.0	52.4	26.20	
RV250/116/462						77.0											4 x M8
RV250/116/493						52.0							2 x M8	62.0	62.0	23.30	
RV250/116/828						63.0											
RV250/120/404		Fig. 1	52.0	178	120	124											
RV250/120/405			63.0														
RV250/124/404	52.0																
RV250/124/405	63.0																

Achtung! * Nicht für öldichten Einbau geeignet
Caution! * Don't use for oil tight assembly

Motorflansch – Ø 300 mm Motor flange – Ø 300 mm

Abmessungen Dimensions [mm]

Typ Type	Bohrbild Pump con.	D1	D2	D3	D4	d1	d2	L	L1	F	G	G1	G2	M	M1	M2								
RV300/130/405	Fig. 1	300	265	230	234	63.0	223	130	20	5	14	M12	2 x M8	62.0	62.0	23.3								
RV300/130/439						50.0							2 x M10	60.0	60.0	14.5								
RV300/130/441						80.0							4 x M8	100.0	72.0	34.5								
RV300/130/446	Fig. 4					36.5							4 x M6	96.2	71.5	32.7								
RV300/130/459						50.0							2 x M10	60.0	60.0	14.5								
RV300/130/499	Fig. 2					65.0							4 x M8	110.0	110.0	32.5								
RV300/144/425	Fig. 4					300	265	230					234	50.8	144	162	20	5	14	M12	4 x M10	137.0	98.4	45.0
RV300/144/444														4 x M8							128.0	42.9		
RV300/144/447														4 x M10							206.0	136.0	103.0	
RV300/144/465														4 x M12	154.0	127.0					48.0			
RV300/162/403/ZFV*														4 x M10	164.0	124.0					50.0			
RV300/162/419/ZFV*														80.0	4 x M12	150.0					150.0	43.2		
RV300/162/423/ZFV*		63.5	4 x M12	188.0	143.0				64.3															
RV300/162/426/ZFV*		105.0	4 x M10	145.0	102.0				48.0															
RV300/162/427/ZFV*		60.0	4 x M12	148.0	127.0																			
RV300/162/442/ZFV*		50.8	4 x M10	137.0	98.4				45.0															
RV300/162/443/ZFV*		60.3	4 x M10	149.4	114.3				49.3															
RV300/162/444/ZFV*		63.5	4 x M12	196.0	142.8				65.1															
RV300/162/449/ZFV*		160.0	4 x M16	200.0	160.0				70.7															

Motorflansch – Ø 350 mm Motor flange – Ø 350 mm

Abmessungen Dimensions [mm]

Typ Type	Bohrbild Pump con.	D1	D2	D3	D4	d1	d2	L	L1	F	G	G1	G2	M	M1	M2							
RV350/173/404	Fig. 1	350	300	250	260	52.0	238	173	26	6	18	M16	2 x M8	62.0	62.0	23.3							
RV350/173/405						63.0							4 x M10	130.0	100.0	41.0							
RV350/173/417	80.0					2 x M10							60.0	60.0	14.5								
RV350/173/439	Fig. 1					50.0							4 x M8	100.0	72.0	34.5							
RV350/173/441	Fig. 4					80.0							4 x M10	145.0	102.0	48.0							
RV350/173/442						105.0							137.0	98.4	45.0								
RV350/173/444						50.8	4 x M8	96.2					71.5	32.7									
RV350/173/446						36.5	128.0	98.4					42.9										
RV350/173/447						50.8	4 x M6	96.2					71.5	32.7									
RV350/173/459						36.5	2 x M10	60.0					60.0	14.5									
RV350/173/499	Fig. 2					50.0	4 x M10	206.0					136.0	103.0									
RV350/205/403/ZFV*	Fig. 4					350	300	250					260	125.0	205	26	6	18	M16	4 x M10	206.0	136.0	103.0
RV350/205/419/ZFV*														60.0						4 x M12	154.0	127.0	48.0
RV350/205/423/ZFV*														85.0						4 x M10	164.0	124.0	50.0
RV350/205/426/ZFV*														80.0	4 x M12					150.0	150.0	43.2	
RV350/205/427/ZFV*														63.5	4 x M12					188.0	143.0	64.3	
RV350/205/442/ZFV*														105.0	4 x M10					145.0	102.0	48.0	
RV350/205/443/ZFV*														60.0	4 x M12					148.0	127.0		
RV350/205/444/ZFV*		50.8	4 x M10	137.0	98.4				45.0														
RV350/205/449/ZFV*		60.3	4 x M10	149.4	114.3				49.3														

Motorflansch – Ø 400 mm Motor flange – Ø 400 mm

Abmessungen Dimensions [mm]

Typ Type	Bohrbild Pump con.	D1	D2	D3	D4	d1	d2	L	L1	F	G	G1	G2	M	M1	M2
RV400/168/441	Fig. 4	400	350	300	300	80.0	284	168	26	6	18	M16	4 x M8	100.0	72.0	34.5
RV400/168/447						50.8							128.0	98.4	42.9	
RV400/168/481						100.0							4 x M10	132.0	88.4	44.2
RV400/196/441						80.0	4 x M8	100.0					72.0	34.0		
RV400/196/442						105.0	4 x M10	145.0					102.0	48.0		
RV400/196/443						60.0	4 x M12	148.0					127.0			
RV400/196/444						50.8	4 x M10	137.0					98.4	45.0		
RV400/196/447						60.3	4 x M8	128.0						42.9		
RV400/196/449						50.8	4 x M10	149.4					114.3	49.3		
RV400/196/465						50.8	4 x M10	128.0					98.4	42.9		

Achtung! * Nicht für öldichten Einbau geeignet
Caution! * Don't use for oil tight assembly

LECKÖL- UND MONTAGEBOHRUNGEN

LEAKAGE- AND INSPECTION BORES

TYPENBEZEICHNUNG

MODEL TYPE

RV350 / 188 / 200 / LB / MB / GI / B14

Pumpenträger Ø
Bellhousing Ø

Pumpenträgerlänge
Length of bellhousing

Bohrbild
Bore pattern

B14= E-Motor-Bauform IMB14
ohne Angabe = E-Motor-Bauform IMB5/V1
B14= E-Motor type IMB14
without specification = E-Motor type IMB5/V1

LB = Leckölbohrung Leakage bore
MB = Montagebohrung Inspection bore
GI = MB mit Gitter MB with grid
ST = MB mit Stopfen MB with plug

POSITIONIERUNG VON LECKÖLBOHRUNGEN (LB) UND MONTAGEBOHRUNGEN (MB) MIT GITTER (GI) UND STOPFEN (ST)

POSITIONING OF LEAKAGE (LB) AND INSPECTION BORES (MB) WITH GRIDS (GI) AND PLUGS (ST)

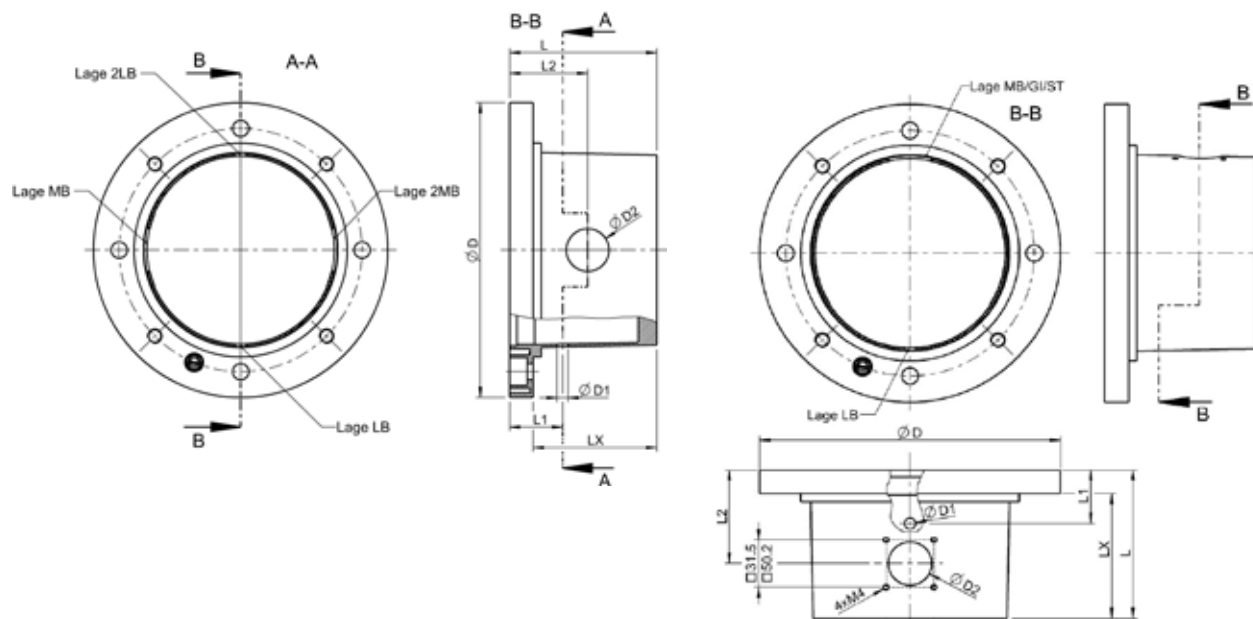

TECHNISCHE DATEN

TECHINCAL DATA

Ø D	E-Motor Baugruppe E-motor	Leckölbohrung Leakage bore		Montagebohrung Inspection bore	
		L1 [mm]	D1 [mm]	L2 [mm]	D2 [mm]
160	71	28	7.5	37	29
200	80 / 90	36		53	
250	100 / 112	43		69	
300	132	45		92	48
350	160 / 180	51		124	
400	200			160	
450	225				
550	250 / 280				
660	315	60			

Bei mehrteiligen Pumpenträgern werden Montagebohrungen auf LX/2 eingebracht.

MONTAGEPLATTEN MOUNTING PLATES

Bei V1-Anordnung Durchführung der Druckleitung zur einfachen Montage und Demontage der Pumpen-Motoren-Einheit.

For leading through pressure line, thus easy mounting and dismounting of the unit pump-bellhousing-motor.

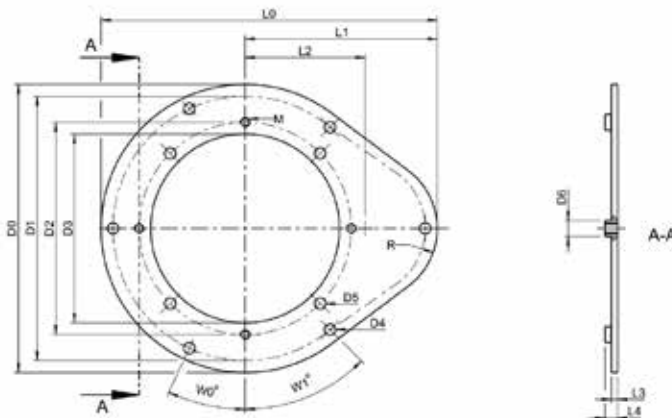

Typ Type	Dichtung 1 Gasket 1	Dichtung 2 Gasket 2	Abmessungen Dimensions [mm]															
			L0	L1	L2	L3	L4	D0	D1	D2	D3	D4	D5	D6	R	M	W0	W1
MP 200	D 200 NBR	D 325 NBR	325	190	140	8	16	250	225	165	147	9.5	11	20	60	M10	-	15
MP 250	D 250 NBR	D 355 NBR	350	190	140	8	16	300	275	215	192	9.5	14	20	60	M12	25	40
MP 300	D 300 NBR	D 420 NBR	420	225	150	8	16	360	330	265	236	14	14	20	90	M12	25	40
MP 350	D 350 NBR	D 475 NBR	475	255	160	10	20	410	380	300	262	14	18	25	110	M16	25	40

PUMPENTRÄGERDICHTUNGEN BELLHOUSING GASKETS

DICHTUNG 1 GASKET 1

Montage zwischen Pumpenträger und Montageplatte
Mounting between bellhousing and mounting plate

Typ Type	Abmessungen Dimensions [mm]			
	D	D1	D2	D3
D 140 NBR	140	115	97	10
D 160 NBR	160	130	112	10
D 200 NBR	200	165	147	12
D 250 NBR	250	215	193	14
D 300 NBR	300	265	237	14
D 350 NBR	350	300	263	19
D 400 NBR	400	350	303	19
D 450 NBR	450	400	353	19
D 550 NBR	550	500	453	19
D 660 NBR	660	600	554	24

MATERIAL: NBR, Gummikork und Pappe
MATERIAL: NBR, rubberized cork and paper

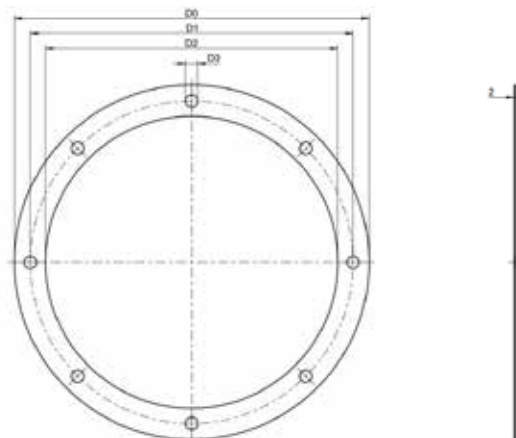

DICHTUNG 2 GASKET 2

Montage zwischen Montageplatte und Behälterdeckel
Mounting between mounting plate and tank lid

Typ Type	Abmessungen Dimensions [mm]					
	L0	L1	D0	D1	D2	R
D 325 NBR	325	250	200	140	10	60
D 355 NBR	350	300	250	140	10	60
D 420 NBR	420	360	300	150	15	90
D 475 NBR	475	410	350	160	20	110

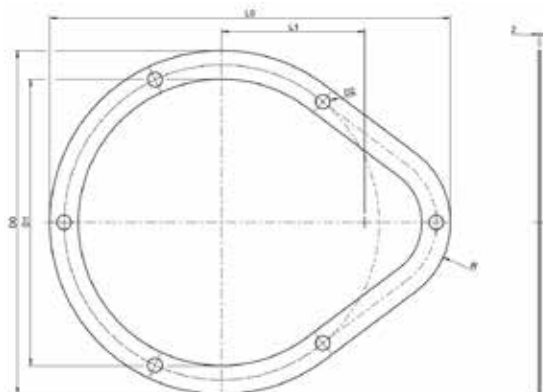

KÜHLPUMPENTRÄGER, SERIE KPV

COOLER BELLHOUSINGS, SERIES KPV



PRODUKTEIGENSCHAFTEN

FEATURES

- Abmessungen gemäß VDMA 24 561
- Gedämpfte Ausführung mit identischer Längenabstufung
- Problemloser Austausch mit gedämpften Pumpenträgern gemäß VDMA 24 561
- Kombinierbar mit Fußflanschen nach VDMA 24 561
- Dimensions acc. to VDMA 24 561
- Noise damping versions in identical lengths
- Easy replacement of dampened bellhousing acc. to VDMA 24 561
- Optional combination with footbrackets acc. to VDMA 24 561

TYPENBEZEICHNUNG

MODEL TYPE

KPV 250 /		120 /		XXXX	D 28	DF		
Kühlpumpenträgertyp Type of cooler bellhousing		Kühlpumpenträgerlängen Lengths of cooler bellhousing			Lüfterrad-Wellen-Ø Fan-shaft-Ø	Ausführung Version		
0.55–1.5 kW	KPV200	KPV200	100	XXXX	D19	0.55–0.75 kW	DF	Gedämpft Damped
2.2–4 kW	KPV250		110		D24	1.1–1.5 kW		
5.5–7.5 kW	KPV300		118		D28	2.2–4 kW		
11–22 kW	KPV350		124		D38	5.5–7.5 kW		
			128		D42	11–15 kW		
		120	D48		18.5–22 kW			
		124						
		128						
		135						
		148						
		175						
		144						
		150						
		155						
		168						
		196						
		188						
		204						
		228						
		256						
				Kennzahl für Pumpenanschluss Bore code for pump connection				
				XXXX	Interne Nummer Internal code			

TECHNISCHE DATEN

TECHNICAL DATA

Betriebsdruck Working pressure	Lastwechsel Load cycle	Max. statischer Druck Max. static pressure
16 bar	1 x 10 ⁶ ; f = 2 Hz	40 bar

Typ Type	Kühlleistung Cooling power p [kW] Δt=40k	Leistung E-Motor E-engine power [kW] n=1500 1/min ⁽¹⁾	Luftdurchsatz Air flow [m ³ /h]	Leistungsaufnahme Fan input power [W]	Schallpegel ⁽²⁾ Noise level ⁽²⁾ [dB(A)]	Korrelation Kühlleistung/Motorleistung Correlation cooling power/E-engine power [%]
KPV200	0.95	0.55–1.50	72	20	52	63–1100
KPV250	2.10	2.20–14.00	260	30	58	53–195
KPV300	3.22	5.50–17.50	430	90	69	43–159
KPV350	5.15	11.00–122.00	780	140	70	23–146

Kühlleistung der Serie KPV in Korrelation zur installierten Motorleistung

- Die zulässige Nenndrehzahl⁽¹⁾ für die Antriebsmaschine beträgt 1500 1/min. Andere Drehzahlen nur nach Rücksprache mit dem Hersteller.
- Schallpegel⁽²⁾ der gedämpften Ausführung gemessen mit Pumpenträger und E-Motor in 1 m Abstand zum Prüfling. Die angegebenen Werte sind als Anhaltswerte zu betrachten, da der tatsächliche Schallpegel abhängig vom eingesetzten Elektromotor schwankt.
- Drehrichtung der Pumpe grundsätzlich **rechts (auf die Pumpenwelle gesehen)**.

Cooling capacity of the series KPV in correlation to the capacity of the installed engine.

- Nominal rotation⁽¹⁾ of driven machine 1500 1/min. In case of different rpm please contact the manufacturer.
- Noise levels⁽²⁾ of damped version are measured with bellhousing and electric motor. Distance to the tested object 1 m. The a. m. values of noise level will be various depending on used electric motor.
- Direction of pump rotation always **clockwise (looking on pump shaft)**.

KÜHLPUMPENTRÄGER VDMA-KOMPATIBEL, RESISTENT GEGEN DRUCKSPITZEN COOLER BELLHOUSING VDMA COMPATIBLE, RESISTANT TO PRESSURE PEAKS

Kühlpumpenträger haben mittlerweile breiten Eingang in die Ölhdraulik gefunden. Die Firma R+L HYDRAULICS GmbH stellt eine innovative Baureihe von Kompakt-Kühlern vor, welche über ein reines 'face-lifting' weit hinausgeht und dem Anwender wesentliche Vorteile bietet – die Kühlpumpenträgerserie KPV.

Nachdem die anfangs auf dem Markt erhältlichen Kühlpumpenträger in der Regel mit einem Rippenrohr als Wärmetauscher bestückt waren, was diese – abgesehen von der unbefriedigenden Kühlleistung – überwiegend auf die Leckkühlung beschränkte, ist die Verwendung prismatischer Kühlelemente heute Stand der Technik. R+L HYDRAULICS hat als erster Hersteller katalogmäßige Kühlpumpenträger mit prismatischen Standard-Kühlelementen eingesetzt. Bei dem hierdurch möglichen Einbau der Kühler in die überwiegend drucklose Rücklaufleitung kann es jedoch bei bestimmten Konstellationen zu Druckschüben kommen, welche mit herkömmlichen Druckmessgeräten nicht zu ermitteln sind.

Dieses ist z.B. häufig der Fall, wenn ein druckbeaufschlagter Zylinder im Millisekundenbereich durch ein Elektromagnetventil zur Rücklaufleitung hin entlastet wird. Durch Massenträgheit und Reibung ist es vielfach nicht möglich, die entstehende Druckschubhöhe vom Kühler fernzuhalten, was in der Vergangenheit bei periodisch wiederkehrenden Druckschüben gelegentlich zum Ausfall des Wärmetauschers führte.

DYNAMISCHE DRUCKBESTÄNDIGKEIT DYNAMIC RESISTANCE TO PRESSURE

Bei der Konzeption der neuen KPV-Baureihe war es deshalb oberstes Gebot, ein Kühlelement zu integrieren, welches ohne Einbußen in der Kühlleistung dynamischen Druckbelastungen standhält. Mittels dynamischer Dauerbelastungsversuche wurde ein Kühlelement entwickelt, welches der anwenderbezogenen Vorgabe von Druckschüben bis zu einer Höhe von 16 bar dauerhaft standhält (Abb. 1).



Abb. 1) Dauerbelastungs-Druckversuche mit Kühlelementen für die R+L HYDRAULICS-Serie KPV bei 16 bar mit 1×10^6 Lastspielen und $f = 2$ Hz
Fig. 1) Dynamic fatigue strain tests with cooling elements for the R+L HYDRAULICS-series KPV at 16 bars with 1×10^6 stress cycles and $f = 2$ Hz



Kühlpumpenträger, Serie KPV
Cooler bellhousing, series KPV

Cooler bell housings are meanwhile well established in the oil hydraulic. The company R+L HYDRAULICS GmbH presents an innovative series of compact coolers, which reaches far beyond a plain "face-lifting" and offers the users substantial advantages – the cooler bellhousing series KPV.

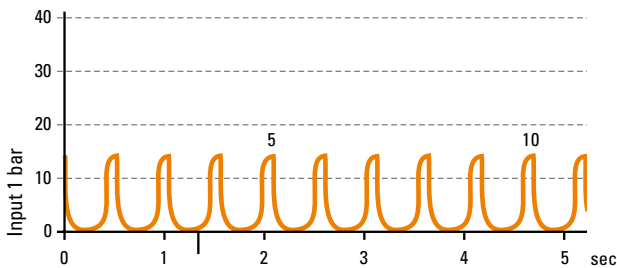
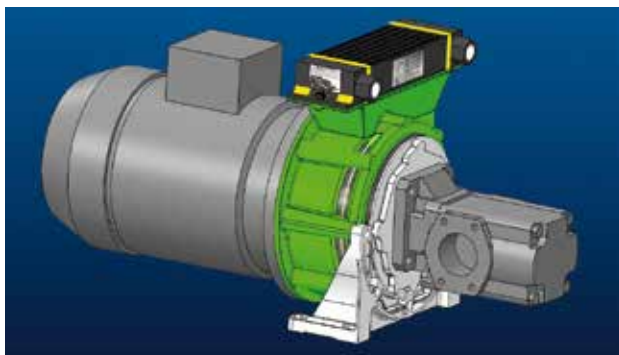
Since the first cooler bell housings on the market were usually equipped with a finned tube as heat exchanger, which – regardless of the unsatisfactory cooling power – chiefly limited to leakage oil cooling, is the application of prismatic cooling elements state-of-the-art today. The herewith given possibility to build the cooler into the mainly pressureless return pipe can however be the cause for pressure peaks, which cannot be detected with customary pressure measuring devices. R+L HYDRAULICS, that was the first manufacturer to bring in cooler bell housings with prismatic standard cooling elements from catalogue.

This is often the case, for instance, when a cylinder under pressure will be unloaded within milliseconds by means of an electromagnetic valve to the return pipe. Because of inertia and friction, it is frequently not possible to protect the cooler from the resulting pressure peak, which has in the past led to occasional breakdowns of the temperature exchanger in the case of recurring pressure peaks.

It became therefore top priority, during the development of the new series KPV, to integrate a cooling element, which withstands dynamic pressure loads without loss of cooling power. According to users' requirements and by means of dynamic fatigue strain tests, a cooling element has been developed, which continually withstands pressure peaks up to 16 bars (Fig. 1).



Abb. 2) Austauschbarkeit der Bauweisen starr, gedämpft, gekühlt nach VDMA 24 561
Fig. 2) Interchangeability of configurations rigid, damped, cooled acc. to VDMA 24 561

DYNAMISCHE DRUCKBESTÄNDIGKEIT (FORTSETZUNG) DYNAMIC RESISTANCE TO PRESSURE (CONTINUED)

1 x 10⁶ Lastspiele werden in der Regel als ausreichend angesehen. Da die Anzahl der Druckspitzen pro Zeiteinheit jedoch im Einzelfall sehr unterschiedlich sein kann, lässt sich schwerlich bestimmen, welcher Lebensdauer 10⁶ Lastspiele entsprechen. Insofern wurden einige Prüfzyklen auf 3.5 x 10⁶ Lastspiele ausgedehnt. Auch in diesen Fällen ergaben sich keine Beanstandungen.

Außerdem wird jeder einzelne Wärmetauscher während der Fertigung mit 40 bar druckgeprüft, was auch dem maximal zulässigen statischen Druck der Kühlelemente entspricht. Des Weiteren wurde bei der Neukonzeption darauf geachtet, dass das Kühlelement gegen äußere Beschädigungen geschützt in das stabile Gussgehäuse des KPV-Kühlers eingebettet ist.

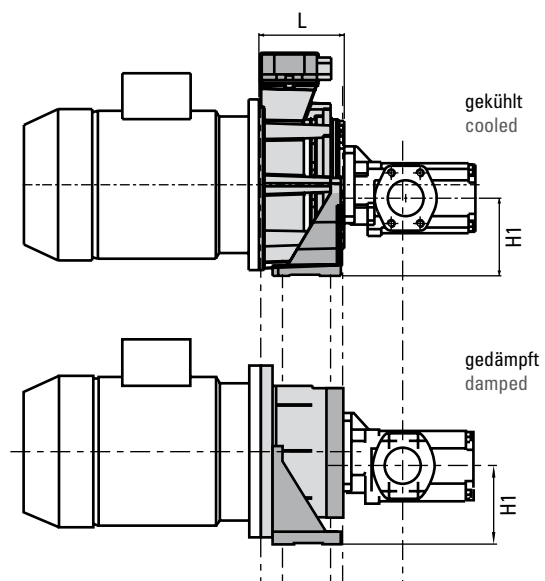
As a rule, 1 x 10⁶ stress cycles will be considered sufficient. However, since the number of pressure peaks per time period can be extremely variable in isolated cases, it is difficult to determine which service life 10⁶ stress cycles correspond to. From that point of view, some of the testing have been extended to 3.5 x 10⁶ stress cycles. In these cases as well, all established results have been satisfactory.

In addition to that, each single heat exchanger will be tested at 40 bar during production, which is equivalent to the highest authorized static pressure for cooling elements. Furthermore, when it came to developing a new concept, great attention has been brought to protecting the cooling element against external damages by embedding it in the sturdy cast-iron casing of the KPV-cooler.

KÜHLEISTUNG COOLING CAPACITY

Aufgrund der einfachen Installation, des platzsparenden Aufbaus und der Einsparung eines elektrischen Lüfterantriebes, haben Kühlpumpenträger zwischenzeitlich breiten Eingang in die Ölhydraulik gefunden, da sie in der Regel den Kühlerfordernissen hinreichend gerecht werden.

Bei Abwesenheit einer externen Wärmequelle rechnet man bei Hydraulikaggregaten bei durchschnittlichen Wirkungsgraden mit Wärmeverlusten von 30 bis 40 % der installierten Motorleistung. Die Wärme, die nicht bereits durch die einzelnen Komponenten des Aggregates, vor allem den Tank, abgegeben wird, muss somit zwecks Vermeidung einer Ölüberhitzung mittels eines zusätzlichen Kühlers abgeführt werden. Auch bei kleineren Tankkapazitäten, beispielsweise im Werkzeugmaschinenbau oder in mobilen Einsatzfällen, hat sich größtenteils eine durchschnittliche zusätzliche Kühlleistung von 20 bis 30 % der installierten Motorleistung als ausreichend erwiesen. Die Kühlleistung der R+L HYDRAULICS-Kühlpumpenträger der Serie KPV erfüllt weitestgehend diese Vorgabe.

Die Abhängigkeit der Kühlleistung von der Öldurchflussmenge ergibt sich aus Abb. 3. Die spezifischen Werte pro 1 K Δt ermöglichen die einfache Umrechnung der tatsächlichen Kühlleistung durch Multiplikation mit dem jeweiligen Δt.

Since as a rule they amply fulfil the cooling requirements, cooler bell housings are meanwhile well established in the oil hydraulic, on account of the easy installation, the space-saving construction and upon the fact that no electric ventilation drive is required.

In the absence of an external source of thermal input, temperature loss of 30 to 40 % of the installed engine performance will be estimated by pump and motor units of average efficiency. All heat, which is not already radiated by the individual components of the unit, especially the tank, will therefore have to be carried off by means of an additional cooler in order to avoid an overheating of the oil. Even by smaller tank capacities, for instance in machine tooling or in mobile operational cases, an average cooling power of 20 to 30 % of the installed engine's power has proved to be largely sufficient. The cooling power of the R+L HYDRAULICS-cooler bell housings of the series KPV fulfils this requirement.

The interdependence between the cooling power and the flowing quantity of the oil follows out of fig. 3. The specific values per 1 K Δt allow the simple conversion of the actual cooling power by multiplication with the respective Δt.



Abb. 3: Spezifische Kühlleistung P/t der Serie KPV in Abhängigkeit vom Öldurchfluss Q und der Temperaturdifferenz Δt = 1 K (Öleintritt zu Lufteintritt).

Fig. 3: Specific cooling power P/t of the series KPV depending on oil flow Q and temperature difference Δt = 1K (oil inlet to air inlet).

AUSTAUSCHBARKEIT NACH VDMA 24 561 INTERCHANGEABILITY ACC. TO VDMA 24 561

Eine weitere Vorgabe für die Konzeption der innovativen R+L HYDRAULICS-Serie KPV war die volle Austauschbarkeit der Einbaumaße nach VDMA 24 561; und zwar nicht nur nach der Einbaulänge, sondern auch nach der Befestigungsposition der Fußverschraubung.

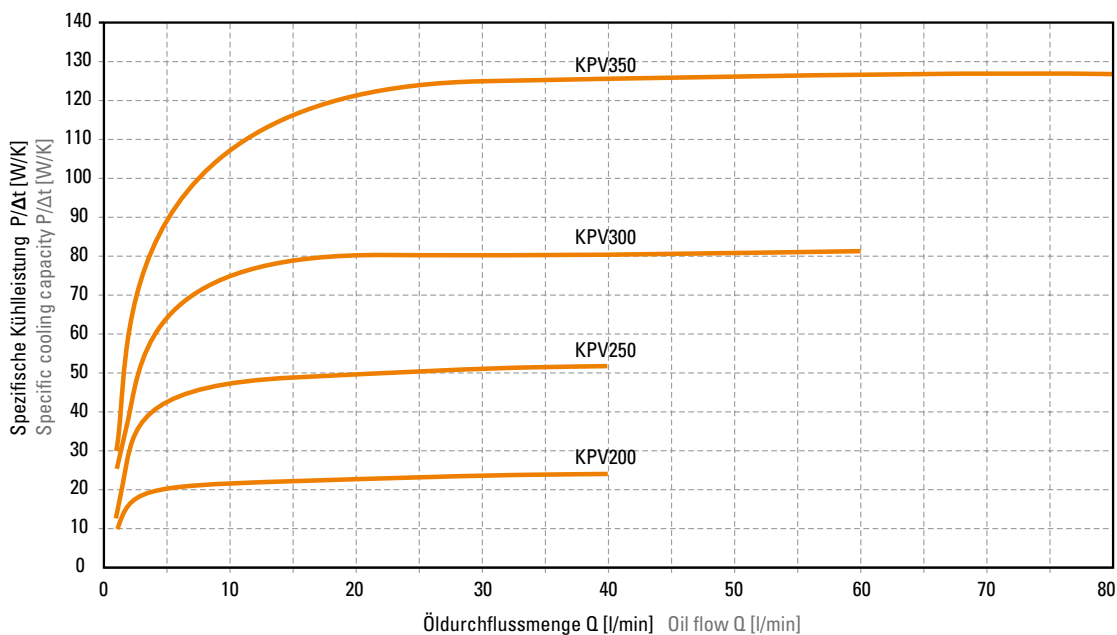
Dieses erlaubt nicht nur die Beibehaltung des gesamten Aufbaus inklusive Verrohrung im Falle von nachträglich erforderlichem Kühlereinsatz. Es erlaubt auch den Projektoren von hydraulischen Anlagen, sich zu jedem späteren Zeitpunkt für das Erfordernis einer Kühlung mit und ohne Geräuschdämpfung zu entscheiden (siehe Abb. 2, Seite 26).

Der R+L HYDRAULICS-Kühlpumpenträger Serie KPV lässt sich sowohl in Horizontalbauweise IMB 35 als auch IMB 5 einbauen, dieses wiederum sowohl mit vertikalem als auch seitlichem Kühlluftaustritt. Ebenso ist der KPV in vertikaler IMV1-Bauweise montierbar.

A further guideline in the conception of the innovative R+L HYDRAULICS-series KPV was the full interchangeability of the mounting dimension acc. to VDMA 24 561 and that, not only according to the fitting length, but also according to the fastening position of the foot brackets.

This does not only make it possible to keep the complete installation, hydraulic piping inclusive, should the use of a cooler become necessary at a later stage. It also allows someone planning hydraulic installations, to decide on the requirements for a cooling with and without noise damper at a later point (see fig. 2, page 26).

The cooler bellhousing series KPV can be mounted horizontally IMB 35-version and IMB 5-version, and with vertical as well as with lateral cooling air discharge. But the KPV can just as well be mounted vertically – IMV1-version.

PUMPENTRÄGER BELLHOUSINGS

Korrekturfaktor k für Δp -Werte in Abhängigkeit von anderen Viskositäten in cSt
Correction factor for the Δp -values depending on other viscosity in cSt

kSt	15.00	22.00	32	46.00	68.00	100.00	150.0	220.0	460.0
k	0.64	0.73	1	1.28	1.62	2.65	3.9	6.9	17.1

Abb. 4
Fig. 4



Abb.5: Durchflusswiderstand des Kühlelements bei einer Ölviskosität von 32 cSt.
Fig. 5: Pressure drop of cooler matrix at the oil viscosity of 32 cSt.

ABMESSUNGEN DIMENSIONS

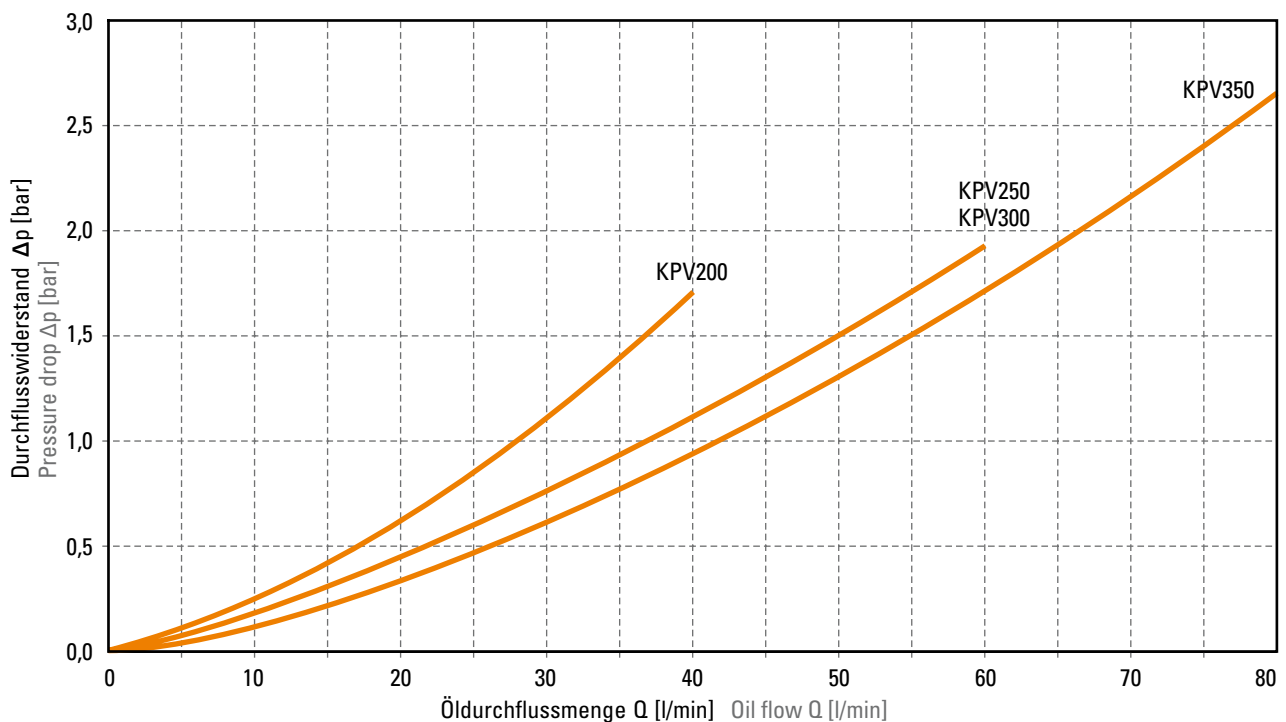
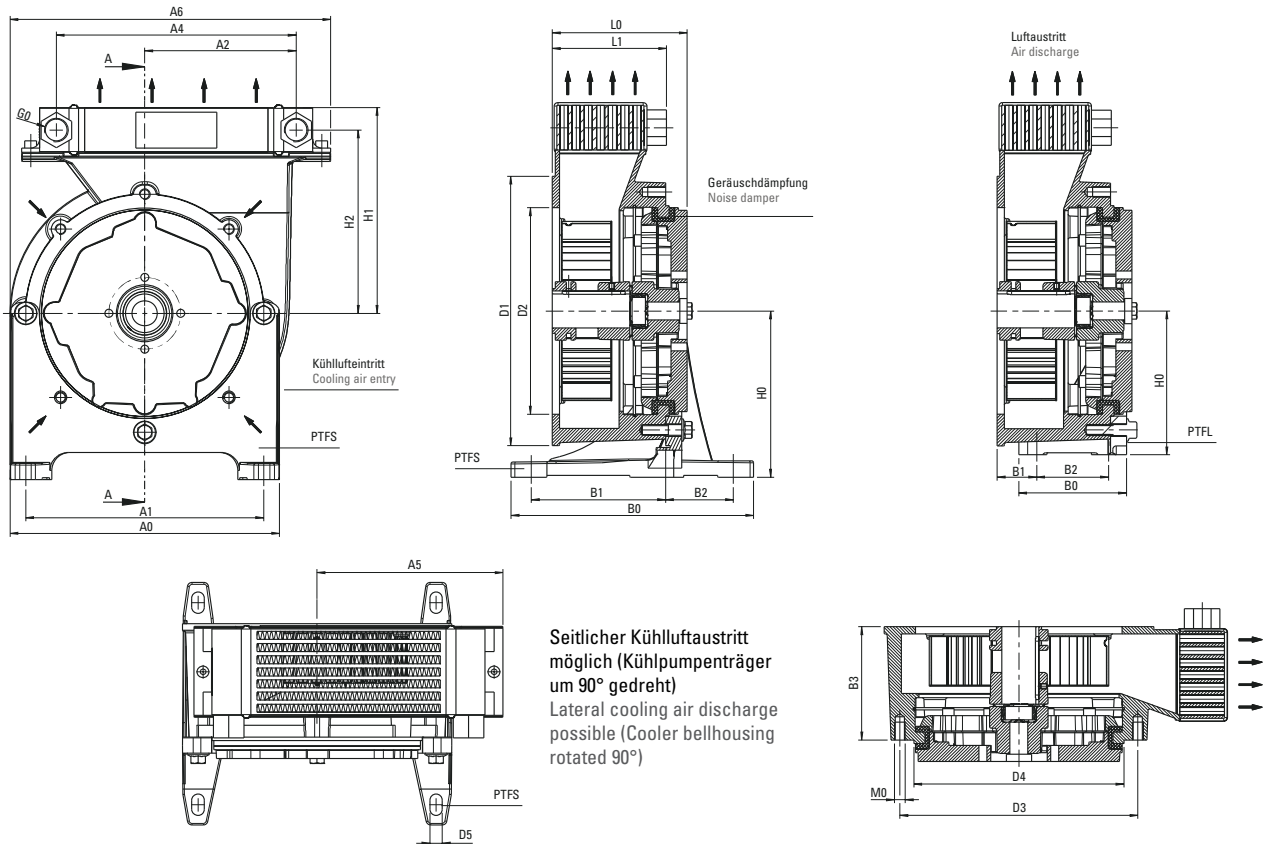

PUMPENTRÄGER BELLHOUSINGS

FUSSFLANSCH OPTIONAL FOOTBRACKET OPTIONAL

Typ Type	Fußflansch PTFE Footbracket PTFE						Fußflansch PTFE Footbracket PTFE					
	A0 [mm]	A1 [mm]	B0 [mm]	B1 [mm]	B2 [mm]	H0 [mm]	A0 [mm]	A1 [mm]	B0 [mm]	B1 [mm]	B2 [mm]	H0 [mm]
KPV200	-	-	-	-	-	-	210	180	90	20	60	112
KPV250	250	215	230	125.0	60.0	155	250	220	110	40	60	132
KPV300	300	265	270	149.5	75.5	185	290	260	120	40	80	160
KPV350	350	300	305	175.0	90.0	235	-	-	-	-	-	-

Typ Type	E-Motor BG Frame size	Leistung Power	Welle Shaft	Abmessungen Dimensions [mm]															
				P [kW]	D x l	L0	L1	A2	A4	A5	A6	B3	H1	H2	D1	D2	D3	D4	D5
KPV200	80	0.55	19 x 24	100	88.0	123.0	204	157.0	262.0	70	176.4	144.9	200	130	165	145	11	10	G½
		0.75		110															
	1.10	118																	
	1.50	124																	
KPV250	90 S+L	2.20	24 x 50	120	108.3	144.5	267	183.0	313.0	102	193.0	168.0	250	180	215	190	14	12	G¾
		3.00		124															
		4.00		128															
	100 L	5.50	28 x 60	135															
		7.50		148															
KPV300	132 S+M	7.50	38 x 80	175	127.0	168.5	267	207.0	357.0	126	229.0	204.0	300	230	265	234	14	12	G¾
				144															
				150															
				155															
KPV350	160 M+L	11.00	42 x 110	188	161.0	201.0	319	243.5	418.5	156	246.0	221.0	350	250	300	260	18	16	G¾
		15.00		204															
	18.50	228																	
	22.00	256																	

PUMPENTRÄGERFÜSSE GGG-40 FOOTBRACKETS GGG-40

Pumpenträgerfüsse aus Sphäroguss GGG-40 sind speziell für folgende Anwendungen entwickelt worden:

- Schwerlastanwendungen
- Mobilhydraulik
- Bergbau, Offshore
- Servomotorische Antriebe

Werkstoff: EN-GJS-400-15
B = 200–660 mm
Ab Lager verfügbar
Andere Größen auf Anfrage
Montageanleitung beachten

Footbrackets made of ductile iron GGG-40 are especially developed for the following applications:

- Heavy duty applications
- Mobile hydraulic
- Mining, Offshore
- Servo motorical drives

Material: EN-GJS-400-15
B = 200–660 mm
Available from stock
Other sizes on request
Please consider the installation manual

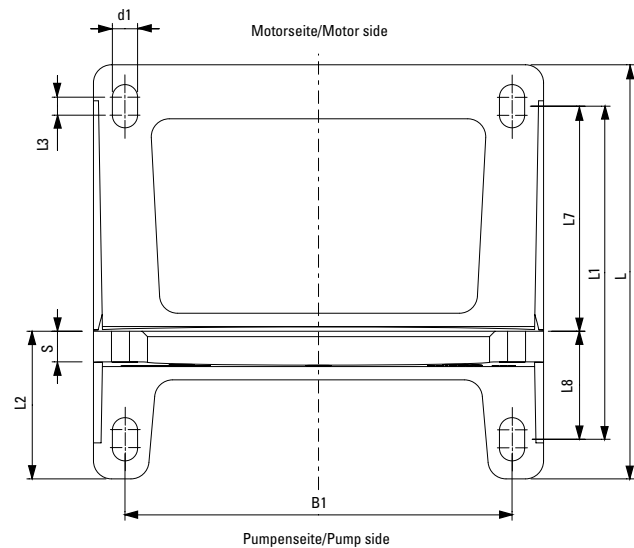
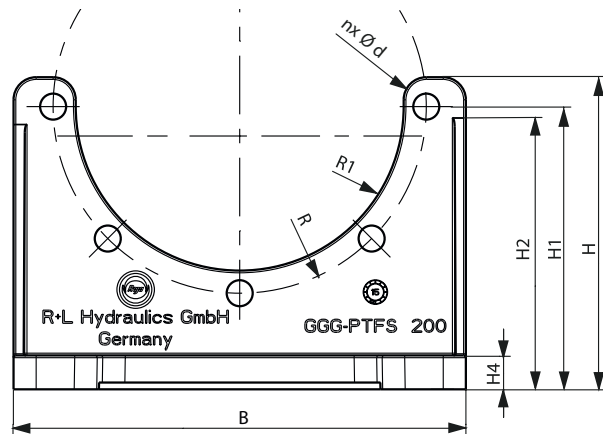

PUMPENTRÄGERFÜSSE GGG-PTFS FOOTBRACKETS GGG-PTFS

Typ Type	Für Pumpenträger For bellhousing	Abmessungen Dimensions [mm]																Gewicht Weight [kg]		
		B	B1	L	L1	L2	L3	L7	L8	H	H1	H2	H4	R	R1	S	n		d	d1
GGG-PTFS 200	RV200/.../...	200	165	185	150	68	8	100	50	138	125	120	15	82.5	72.50	12	5	11.5	11	3.523
GGG-PTFS 250	RV250/.../...	250	215	230	185	82	10	125	60	165	155	150	15	107.5	95.25	17				14.0
GGG-PTFS 300	RV300/.../...	300	265	270	225	98		150	75	195	185	185	18	132.5	117.25	20		17.155	21.585	
GGG-PTFS 350	RV350/.../...	350	300	305	265	110		175	90	252	235	232	22	150.0	130.50	22				18.0
GGG-PTFS 400	RV400/.../...	400	350	350	300	125	12	200	100	275	260	240	22	175.0	150.50	22		18.0	18	
GGG-PTFS 450	RV450/.../...	450	400	385	335	133		225	110	310	295	280	22	200.0	176.00	25	9			27.362
GGG-PTFS 550	RV550/.../...	550	500	465	415	165		275	140	370	350	318	25	250.0	226.00	30		20.0	22	
GGG-PTFS 660	RV660/.../...	660	600	555	495	195	18	330	165	405	380	348	30	300.0	276.00	30	20.0			22

Die volle Belastbarkeit wird nur erreicht, wenn alle vorhandenen Befestigungsbohrungen verschraubt werden!
The full load capacity is reached, only if all mounting holes are being used!

VORTEILE BEI MONTAGE MIT FUSSFLANSCH ADVANTAGES OF FOOTBRACKET ASSEMBLY

1. Reduzierung der Motor-Lagerhaltung auf IM B5/V
 2. Einfacher Austausch des E-Motors.
 3. Aufbau von Pumpe und Verrohrung auch ohne Motor möglich.
 4. Die bei Fußmotoren teilweise notwendige Unterfütterung entfällt.
-
1. Storage reduction to electric motors, frame IM B5/V1 (without feet).
 2. Simple exchange of the electric motor.
 3. Assembly of pump and pipes without electric motors possible.
 4. No shimming of motor feet.

Das R+L HYDRAULICS-Konzept: starr, gedämpft, gekühlt R+L HYDRAULICS – the general solution concept: rigid, dampened, cooled

Identische Einbaumaße L, B1, B2, H1 bei Verwendung der Fußflansch- Baureihe PTFL.

Identical dimensions L, B1, B2, H1 in case of using footbrackets series PTFL.

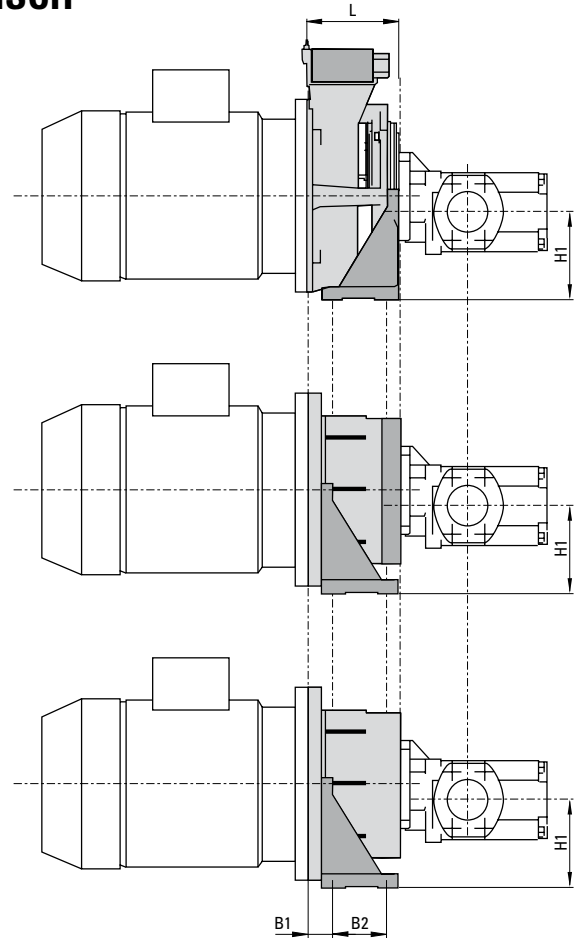

LEICHTE BAUREIHE PTFL LIGHT VERSION PTFL

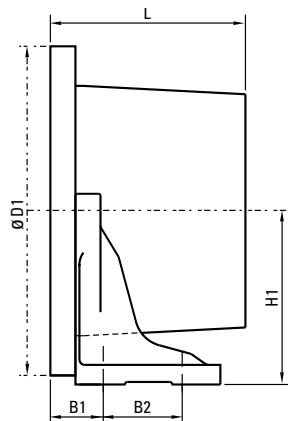

SCHWERE BAUREIHE PTFS HEAVY DUTY VERSION PTFS

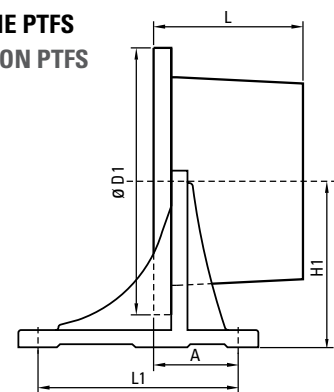

E-Motor Baugröße Frame Size	Fußflansch Footflange	Flansch Flange	Ø D1 [mm]	B7 [mm]	B2 [mm]	H1 [mm]	L
71	PTFL 160	160		20	50	100	siehe Pumpen- träger Maßblatt see bellhousing diagram
80	PTFL 200	200		20	60	112	
90 S+L							
100 L	PTFL 250	250		40	60	132	
112 M							
132 S+M							

E-Motor Baugröße Frame Size	Fußflansch Footflange	Flansch Flange	Ø D1 [mm]	A [mm]	L7 [mm]	H1 [mm]	L
100 L	PTFS 250	250		79	185	155	siehe Pumpen- träger Maßblatt see bellhousing diagram
112 M							
132 S+M							
160 M	PTFS 350	350		116	265	235	
180 L							
200 L	PTFS 400	400		126	300	260	
225 S+M	PTFS 450	450		136	335	295	
250 M	PTFS 550	550		166	415	350	
280 S+M							
315 S+M+L	PTFS 660	660		197	495	380	

PUMPENTRÄGERFÜSSE BAUREIHE PTFL / PTFS FOOTBRACKETS SERIES PTFL / PTFS

nach VDMA 24 561, für Motorbauform IM B5
acc. to VDMA 24 561 for bellhousings, motor type IM B5

PUMPENTRÄGER BELLHOUSINGS

PTFL LEICHTE BAUREIHE PTFL LIGHT VERSION

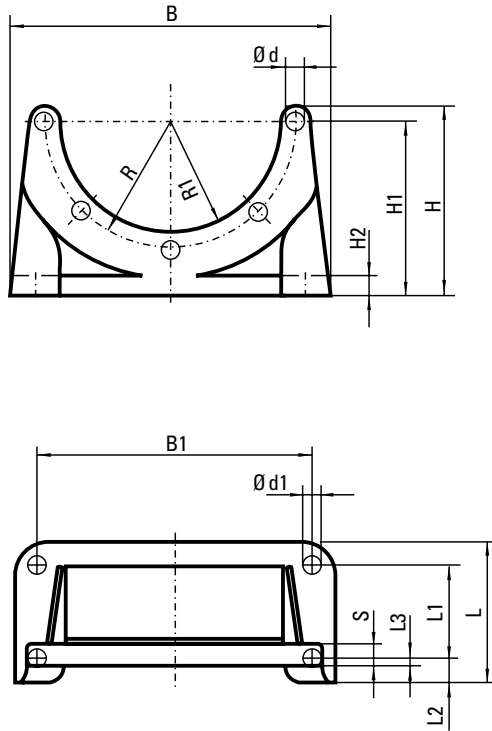

PTFS SCHWERE BAUREIHE PTFS HEAVY DUTY VERSION

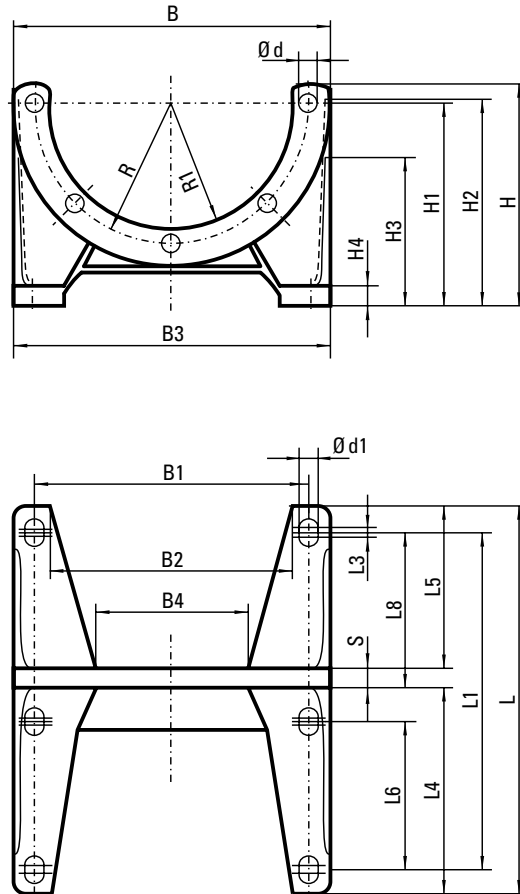

Typ Type	Abmessungen Dimensions [mm]																							
	B	B1	B2	B3	B4	L	L1	L2	L3	L4	L5	L6	H	H1	H2	H3	H4	R	R1	S	d	d1	L	L8
PTFL 160	160	140				80	50	15	7				108	100	10			65.0	55.00	12	9	9		
PTFL 200	210	180				90	60	15	4				122	112	12			82.5	72.50	14	11	11		
PTFL 250	250	220				110	60	25	21				145	132	15			107.5	95.00	19				
PTFL 300	290	260				120	80	24	20				172	160	20			132.5	117.00	18				
PTFS 250	250	215	193	250	162	260	185		10	147.5	67.5	110	167	155	155	120	15	107.5	95.15	15	14	14	15	60
PTFS 300	300	265	243	300	207	270	225		10	172.0	80.0	130	197	185	185	145	18	132.5	117.25	18			20	75
PTFS 350	350	300	260	350	210	305	265		12	195.0	92.0	150	255	235	235	184	18	150.0	130.00	18			25	90
PTFS 400	400	350	320	400	260	350	300		12	225.0	105.0		277	260	232	220	20	175.0	151.00	20				100
PTFS 450	450	400	364	450	317	385	335		12	250.0	113.0		312	295	272	238	20	200.0	176.00	22	18	18		110
PTFS 550	550	500	454	550	401	465	415		12	300.0	140.0		365	350	335	285	25	250.0	226.00	25				140
PTFS 660	660	600	550	660	486	555	495		18	360.0	165.0		400	380	360	308	30	300.0	276.00	30	22	22		165

PTFS 800 auf Anfrage. Bitte beachten Sie unsere Montageanleitung. Der Pumpenträger muss mit sämtlichen Befestigungsbohrungen des Fußflansches verschraubt werden, um die volle Belastbarkeit des PTFL/PTFS zu gewährleisten!

PTFS 800 on request. Please note our assembly instruction. The bellhousing must be assembled with all mounting holes of the foot bracket, to ensure the maximum loading capacity of the PTFL/PTFS!

DÄMPFUNGRINGE

DAMPING RINGS

TYPENBEZEICHNUNG

MODEL TYPE

DR - V1 / B5 - 300 / VS

- Für vertikale und horizontale Montage
 - Kostengünstige Schallreduzierung durch Entkoppelung
 - Mineralölbeständigkeit durch NBR-Gummimischung
 - Anvulkanisierte Dichtlippe, keine zusätzliche Dichtung erforderlich
- Vertical and horizontal mounting
 - Low cost noise level reducing as a result of rubber flexible separation
 - Resistance against mineral-oil due to NBR-rubber
 - Moulded ring-sealing, no additional sealing required

Standardausführung Standard version	200		VS-Ausführung VS-Design	Ausführung Design	
	250			-	Standardausführung Standard version
	300	300		VS	VS-Ausführung VS-Design
	350	350			
	400	400			
	450	450			
	550	550			
660	660				

ABMESSUNGEN

DIMENSIONS

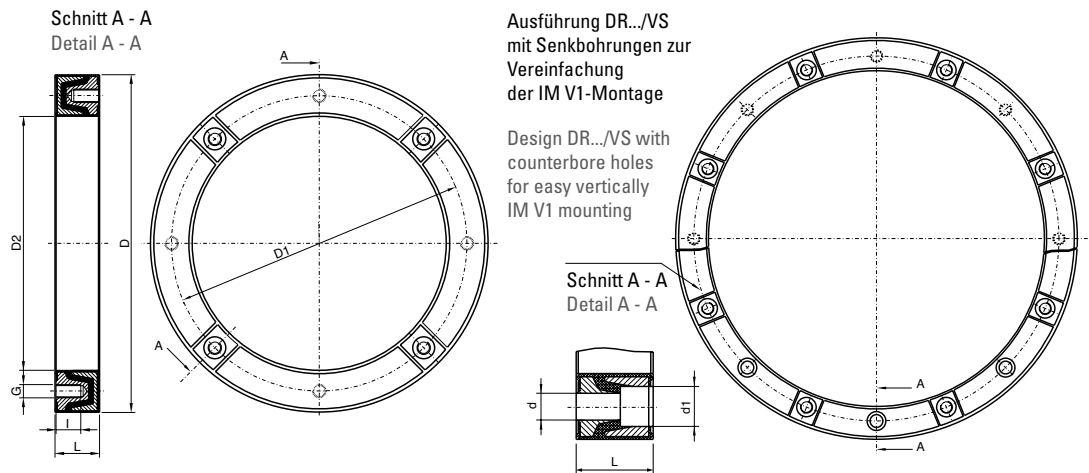

TECHNISCHE DATEN

TECHNICAL DATA

Dämpfungsring Typ Damping rings	IEC-Motor Baugröße IEC-Motor frame size	Abmessungen Dimensions [mm]									
		D	D1	D2	G	I	L	d	d1		
DR-V1/B5-200	80 / 90S / 90L	200	165	146	4 x M10	18	40	-	-		
DR-V1/B5-250	100L / 112M	250	215	191	4 x M12	22	45				
DR-V1/B5-300	132S / 132M	300	265	235			50				
DR-V1/B5-350	160M / 160L / 180M / 180L	350	300	261	4 x M16	29	60				
DR-V1/B5-400	200L	400	350	301			50				
DR-V1/B5-450	225S / 225M	450	400	352	8 x M16	32	60				
DR-V1/B5-550	250M / 280S / 280M	550	500	452			65				
DR-V1/B5-660	315S / 315M	660	600	552	8 x M20	33	65				
DR-V1/B5-300/VS	132S / 132M	300	265	235	4 x M12	22	50			4 x 14	4 x 20
DR-V1/B5-350/VS	160M / 160L / 180M / 180L	350	300	261	4 x M16		60			4 x 18	4 x 26
DR-V1/B5-400/VS	200L	400	350	301		8 x M16	29	50	8 x 18	8 x 26	
DR-V1/B5-450/VS	225S / 225M	450	400	352	60						
DR-V1/B5-550/VS	250M / 280S / 280M	550	500	452	8 x M20	32	65	8 x 22	8 x 31		
DR-V1/B5-660/VS	315S / 315M	660	600	552			65				

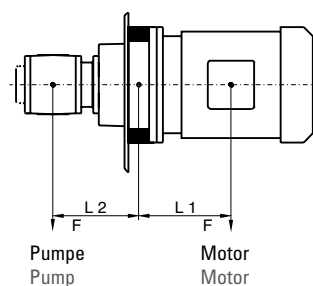

Zulässige radiale Gewichts- und Biegebelastung bei einer Betriebstemperatur von + 60 °C
Permissible radial weight and bending loads with an operating temperature of + 60 °C

$$F_{zul} \geq F_{Pumpe} + F_{Motor}$$

$$F_{zul} \geq F_{Pump} + F_{Motor}$$

$$Mb_{zul} \geq F_{Motor} \times L1 - F_{Pumpe} \times L2$$

$$Mb_{zul} \geq F_{Motor} \times L1 - F_{Pump} \times L2$$

DR-Typ DR-Type	200	250	300	350	400	450	550	660
F_{zul} [N]	385	755	1520	3780	5040	6800	13390	24720
Mb_{zul} [Nm]	30	65	175	740	1100	1600	4400	9000

DÄMPFUNGSSCHIENEN

DAMPING RODS

PRODUKTEIGENSCHAFTEN

FEATURES

- Für Elektromotoren Bauform IM B35 und Fußflansche nach VDMA 24 561
- Ausgelegt für die Gewichtsbelastung bei horizontalem Einbau
- Schallreduzierend und schwingungsdämpfend
- Mineralölbeständigkeit durch NBR-Gummimischung
- For electric motors with frame size IM B35 and footbrackets acc. VDMA 24 561
- Dimensioned for loads in case of horizontal mounting
- Noise absorbing and vibration damping
- Resistance against mineral-oil because of NBR-rubber

TYPENBEZEICHNUNG

MODEL TYPE

PTFSDL		660 Nenngröße (siehe Tabelle unten) Nominal size (see table below)
Dämpfungsschiene-Typ Type of damping rod		
Elektromotoren Electric motors	MDL/DSM	
Fußflansche schwer Footbrackets heavy duty	PTFSDL	
Fußflansche leicht Footbrackets light	PTFLDL	

ABMESSUNGEN

DIMENSIONS

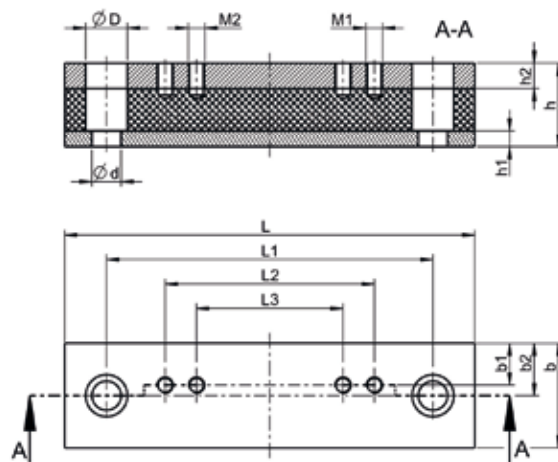

TECHNISCHE DATEN

TECHNICAL DATA

AUSFÜHRUNG MDL FÜR ELEKTROMOTOREN TYPE MDL FOR ELECTRIC MOTORS

Dämpfungsschiene Damping rods	Motortyp Motor type	L [mm]	L1 [mm]	L2 [mm]	L3 [mm]	h [mm]	h1 [mm]	h2 [mm]	b [mm]	b1 [mm]	b2 [mm]	d [mm]	D [mm]	M1	M2	
MDL 71	71	196	90	156	-	40	8	12	50	21	25	14	20	M6	-	
MDL 80	80		100							22				M8		
MDL 90S	90S		125							24						
MDL 90L	90L	240	140	20		M10										
MDL 100L	100L		178	24												
MDL 112M	112M	285	210	300		-	45	15	15	70	28	35	18	26		M12
MDL 132S	132S		254	370							20					
MDL 132M	132M	178	245	20												
MDL 160M	160M	416	279	400			60	15	15	70	35	22	32	M16		
MDL 160L	160L		241	370												
MDL 180M	180M		279	400												
MDL 180L	180L	446	305	430	60		15	15	70	35	22	32	M16			
MDL 200L	200L		286	430												
MDL 225S	225S		311	445												
MDL 225M	225M	496	349	445	60		15	15	70	50	50	25	40	M20		
MDL 250M	250M		368			530										
MDL 280S	280S	580	419	610		70									15	15
MDL 280M	280M	406	610													
MDL 315S	315S	457	610													
MDL 315M	315M	720	508	670	70	15	15	70	60	75	25	40	M24			
MDL 315L	315L		508	670												

TECHNISCHE DATEN

TECHNICAL DATA

AUSFÜHRUNG DSM FÜR ELEKTROMOTOREN TYPE DSM FOR ELECTRIC MOTORS

Dämpfungsschiene Damping rod	Motortyp Motor type	L [mm]	L1 [mm]	L2 [mm]	L3 [mm]	h [mm]	h1 [mm]	h2 [mm]	b [mm]	b1 [mm]	b2 [mm]	d [mm]	D [mm]	M1	M2
DSM80	80	176	146	100	-	40	8	12	50	22.0	25	14	20	M8	-
DSM90S	90S	196	156							24.5					
DSM100L/DSM112M	100L/112M	240	205	140	178	45	15	15	70	22.0	35	22	33	M10	M10
DSM132S/DSM132M	132S/132M	280	245	140						20.0					
DSM200L	200L	492	430	305	-	60	15	15	70	35.0	35	22	33	M16	-
DSM225S	225S			286											
DSM225M	225M		445	311											
DSM250M	250M			349											
DSM280S/DSM280M	280S/280M	614	570	368	419	419	100	50.0	50	50	22	33	M20	M20	
DSM315S/DSM315M	315S/315M			406									457		
DSM315L	315L	704	660	508	-	-	-	-	120	60.0	60	-	-	M24	M24

FÜR FUSSFLANSCH E FOR FOOTBRACKETS

Dämpfungsschienen Damping rods	Für Typ For type	L [mm]	L1 [mm]	L2 [mm]	L3 [mm]	h [mm]	h1 [mm]	h2 [mm]	b [mm]	b1 [mm]	b2 [mm]	d [mm]	D [mm]	M1	M2						
PTFSDL 250	PTFS 250	290	185	260	-	40	8	12	50	20	25	14	20	M12	-						
PTFSDL 300	PTFS 300	350	225	300																	
PTFSDL 350	PTFS 350	375	265	340					60	15	15					70	30	35	18	26	M16
PTFSDL 400	PTFS 400	420	300	385																	
PTFSDL 450	PTFS 450	455	335	420	-	60	15	15	70	30	35	18	26	M16							
PTFSDL 550	PTFS 550	535	415	500																	
PTFSDL 660	PTFS 660	660	495	610	-	60	15	15	70	30	35	18	26	M16							
PTFSDL 660	PTFS 660	660	495	610																	
PTFLDL 160	PTFL 160	176	50	130	-	40	8	12	50	10	25	14	20	M8	-						
PTFLDL 200	PTFL 200		60							15				M10							
PTFLDL 250	PTFL 250	230	140	15																	
PTFLDL 300	PTFL 300	270	80						170	M12											



DER DIREKTE DRAHT ZU R+L HYDRAULICS

Durchwahl für Deutschland: +49 2392 509-155
E-Mail Deutschland: verkauf@rl-hydraulics.com

Durchwahl Export: +49 2392 509-130
E-Mail Export: sales@rl-hydraulics.com



THE DIRECT CONTACT TO R+L HYDRAULICS

Direct dialling for Germany: +49 2392 509-155
E-Mail Germany: verkauf@rl-hydraulics.com

Direct dialling export: +49 2392 509-130
E-Mail export: sales@rl-hydraulics.com

R+L HYDRAULICS

R+L HYDRAULICS GmbH
Friedrichstraße 6
D-58791 Werdohl
Phone: +49 2392 509-0

www.rl-hydraulics.com
info@rl-hydraulics.com