



# DIAMOND DRESSERS

INNOVATOR IN TECHNOLOGY





DIAMOND DRESSERS  
INNOVATOR IN TECHNOLOGY



**SDD ( Single-point Diamond Dressers )**

Manufactured by sintering a selected diamond crystal with metal matrix into a steel shank.

**FDD ( Forming Diamond Dressers )**

Manufactured by shaping a selected high-quality diamond.

**MDD ( Multi-point Diamond Dressers )**

Two or more selected diamonds are set in metal matrix.

**IDD ( Impregnated Diamond Dressers )**

Manufactured by sintering selected diamond particles with metal matrix.

**PCD dressers**

Manufactured by brazing Poly-crystalline diamonds.



## Contents

Materials -----	4
Comparison chart by material -----	5
SDD (Single-point Diamond Dressers) -----	6
(Natural / Synthetic)	
FDD (Forming Diamond Dressers) -----	9
(Roof / Chisel / Cone)	
MDD (Multi-point Diamond Dressers) -----	12
(Natural / Blade types)	
IDD (Impregnated Diamond Dressers) -----	16
(Non-patterned IDD / Patterned IDD)	
Special tools -----	18
(Burnishing tools / PCD / Contact gauges)	

Applications	Diamond dressers
<ul style="list-style-type: none"> <li>• Used for straight type conventional abrasive wheels.</li> <li>• Used for simple profile, thread and gear grinding abrasive wheels.</li> </ul>	SDD, IDD
<ul style="list-style-type: none"> <li>• Used for straight type and conventional abrasive profile wheels.</li> <li>• Able to dress complex forms and profiles with precision.</li> </ul>	FDD, MDD
<ul style="list-style-type: none"> <li>• Ideal for dressing larger and wider conventional abrasive wheels.</li> <li>• Used for dressing conventional surface and center-less abrasive wheels.</li> </ul>	MDD, IDD
<ul style="list-style-type: none"> <li>• Used for dressing complex forms and profiles.</li> </ul>	PCD dressers

### Expression of DIPROTEX diamond dressers

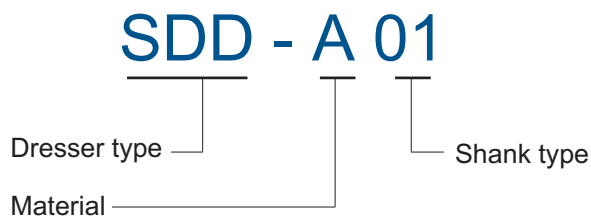

# Materials

## Synthetic diamonds

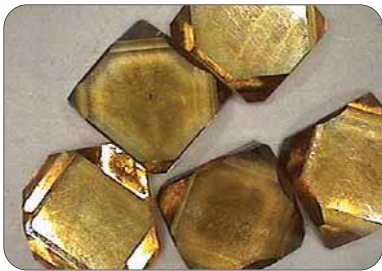

**F: MONO CRYSTAL**

Almost same property as natural diamond  
Applications : SDD, FDD

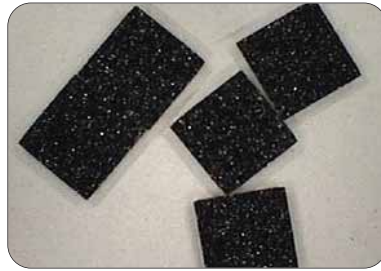

**G: CVD ( Chemical Vapor Deposition )**

Applications : SDD, FDD, MDD

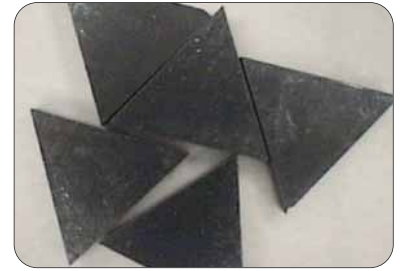

**H: PCD**

Applications : PCD dresser

## Natural diamonds



**A: OCTAHEDRON**

Point angle 90 degree / Applications :  
SDD, Natural diamond-MDD



**B: DODECAHEDRON**

Point angle 120 degree / Applications :  
SDD, Natural diamond-MDD



**C: ELONGATED**

Oblong shape  
Applications : FDD cone type



**D: MACCLE**

Triangle shape  
Applications : FDD chisel type



**E: SHAPE**

Round, Flat shape  
Applications : FDD chisel type



# Comparison chart by material

Property	Natural Diamond	Mono Crystal	CVD Diamond	PCD	WC (K10)
Thermal conductivity (W/mK)	2000	2000	1000	560	110
Hardness (GPa)	50~100	50~100	80~100	50	18
Toughness (MPam-m <sup>½</sup> )	3.4	3.4	5~6	8~9	10.5
Tensile strength (Gpa)	1000~3000	1000~3000	400~800	1260	-
Compressive strength (Gpa)	9	9	16	7.6	6.1
TRS (Gpa)	2.9	2.9	1.3	1.2	2.4

## ● Recommended diamond dresser by wheel shape ●

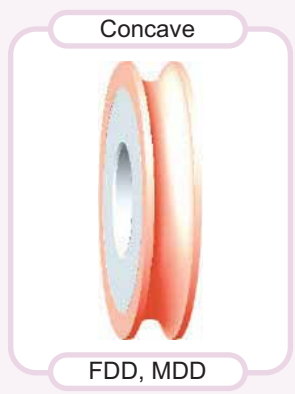

# DIAMOND DRESSER

# SDD

Single-point  
Diamond Dresser



## **S**ingle-point diamond dressers :

Single-point diamond dressers are versatile and economical to dress straight type conventional abrasive wheels. Customers can choose diamond carat and materials dependent upon working conditions such as wheels size, wheel width, depth of cut, etc.

### Recommended Depth of Cut :

Wheel grit size 20~60 : 0.025 mm ~ 0.05 mm

Wheel grit size 80~140 : 0.015 mm ~ 0.025

Wheel grit size 160~200 : 0.01 mm ~ 0.015

### Recommended Diamond Carat :

Wheel Diameter 100~150 : 1/7 ct

Wheel Diameter 175~250 : 1/5 ct

Wheel Diameter 300~350 : 1/4 ct

Wheel Diameter 350~400 : 1/3 ct

Wheel Diameter 400~500 : 1/2 ct

Wheel Diameter 500~600 : 3/4 ct

Wheel Diameter 600~ : 1 ct





## Natural

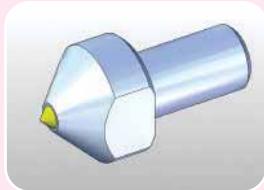

### Available diamond :

- A ( Octahedron )
- B ( Dodecahedron )

### Available carat :

Max 1 ct ~ Min 1/30 ct

## Synthetic

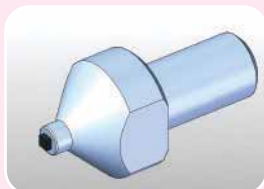

### Available diamond :

- F ( Mono Crystal )
- G ( CVD )

### Available size :

- 0.6 mm X 0.6 mm X 3 mm
- 0.8 mm X 0.8 mm X 3 mm
- 1.0 mm X 1.0 mm X 3 mm
- 1.5 mm X 1.5 mm X 3 mm

## Specifications

### ● SDD-A01 ●

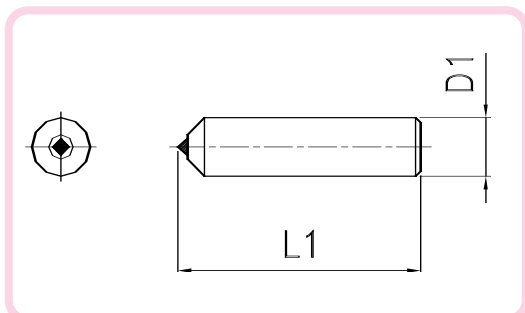

	D1	L1
Standard	12	90

### ● SDD-A02 ●

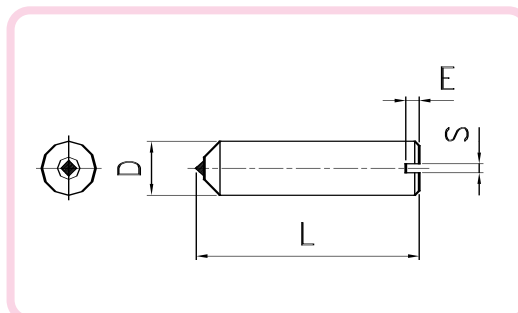

	L	D	S	E
Standard	50	10	1.5	2

### ● SDD-A03 ●

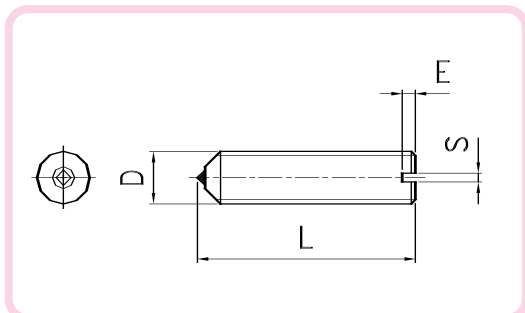

	Pich	L	S	E
Standard	M8X1.0	16	1.0	2

### ● SDD-A09 ●

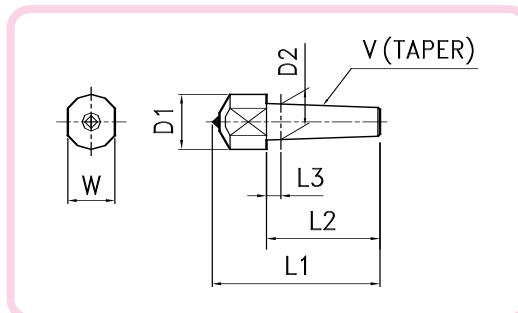

	D1	L1	L2	D2	V
Standard	18	60	42	12	MT1

# Specifications

● SDD-A10 ●

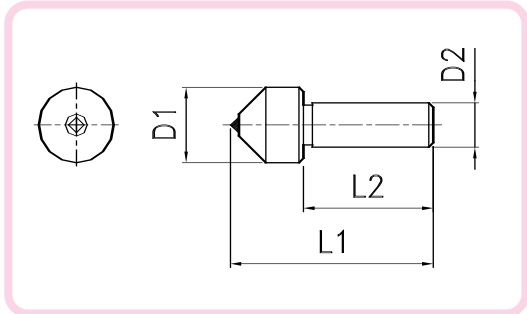

	D1	D2	L1	L2
Standard	12	8	42	25

● SDD-A12 ●

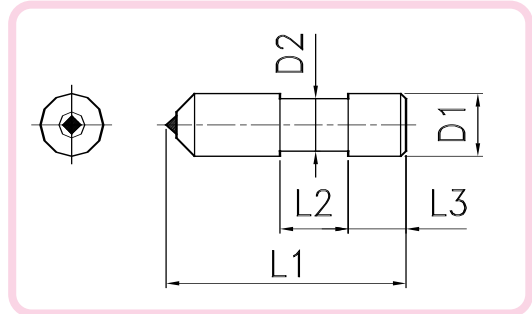

	D1	D2	L1	L2	L3
Standard	10	8	43	22	8

● SDD-A13 ●

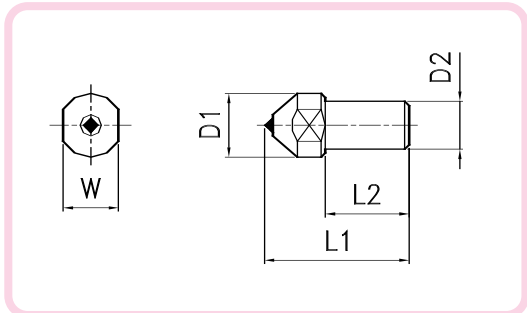

	D1	D2	L1	L2	W
Standard	16	11	37	22	14

● SDD-A14 ●

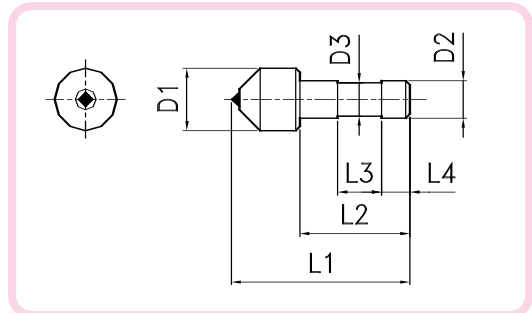

	D1	D2	D3	L1	L2	L3
Standard	16	11	8	34	19	8

● SDD-A18 ●

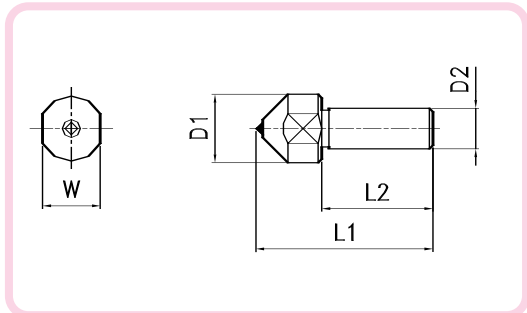

	D1	D2	L1	L2	W
Standard	16	11	29	15	14





# DIAMOND DRESSER

## FDD

Forming  
Diamond Dresser



### F forming Diamond Dressers :

Forming diamond dressers are used for dressing specific forms into conventional abrasive wheels requiring longer tool life.

Natural diamonds have very high resistance while they could be easily broken and have unsteady tool life. On the other hand, synthetic diamonds have steady tool life. Generally, the bigger radius of diamonds can ensure longer tool life. However, the much bigger radius can get grinding wheels to be burned because it makes the grinding wheels' grit blunt.

Recommended angle and radius (For chisel dresser )

Rough grinding : R 0.3~0.5 , 50° ~ 60°

Finish grinding : R 0.1~0.25 , 30° ~ 45°



## Roof

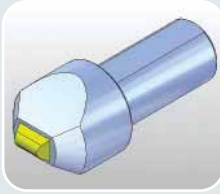

Available diamond :  
D ( Maccle ), E ( Shape ),  
F ( Mono crystal ),  
G ( CVD ), H ( PCD )

Available carat :  
Max 3/4 ct ~ Min 1/4 ct

## Chisel

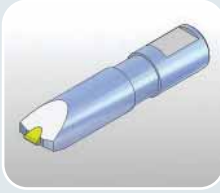

Available diamond :  
D ( Maccle ), E ( Shape ),  
F ( Mono crystal ),  
G ( CVD )

Available carat :  
Max 3/4 ct ~ Min 1/4 ct

## Cone



Available diamond :  
C ( Elongated ),  
G ( CVD )

Available carat :  
Max 1/2 ct ~ Min 1/4 ct

# Specifications

### ● FDD-C01 ●

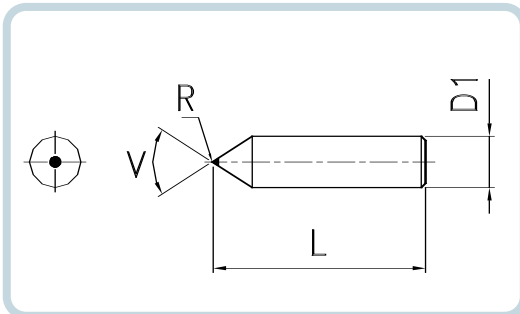

	D1	L	V	R
Standard	11	30	90	0.3

### ● FDD-C13 ●

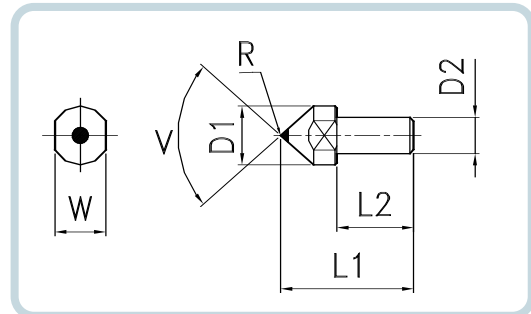

	D1	D2	L1	V	R
Standard	15	11	23	90	0.3

### ● FDD-C14 ●

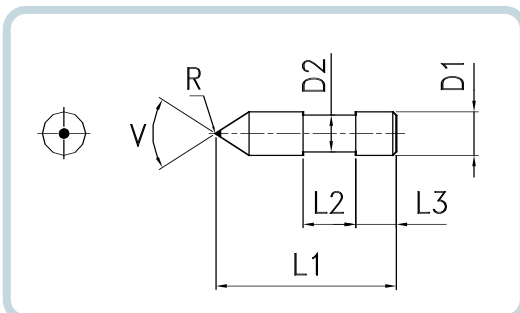

	D1	D2	L1	V	R
Standard	10	8	43	90	0.3

### ● FDD-C19 ●

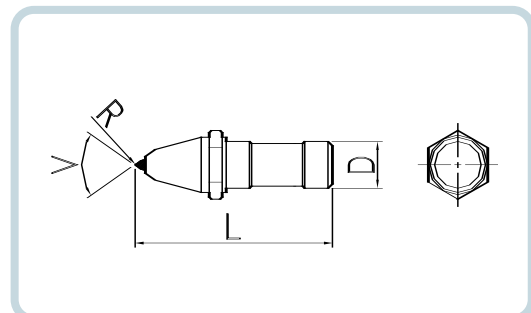

	D	L	V	R
Standard	11	46.5	70	0.3

● FDD-D01 ●

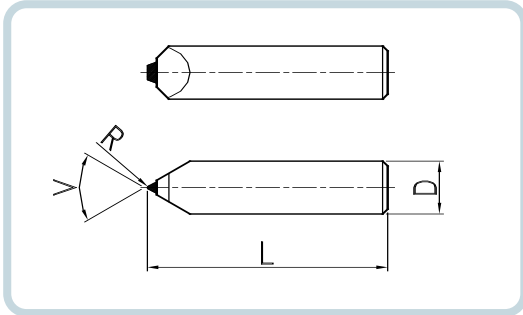

	D	L	V	R
Standard	11	40	55	0.2

● FDD-D12 ●

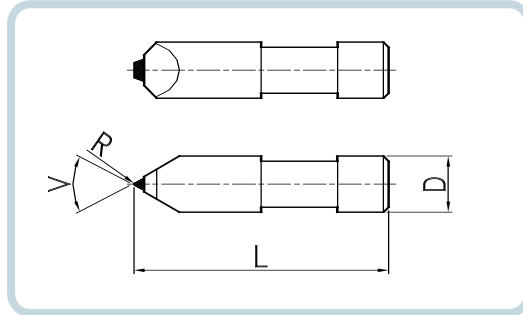

	D	L	V	R
Standard	10	45	55	0.2

● FDD-D05 ●

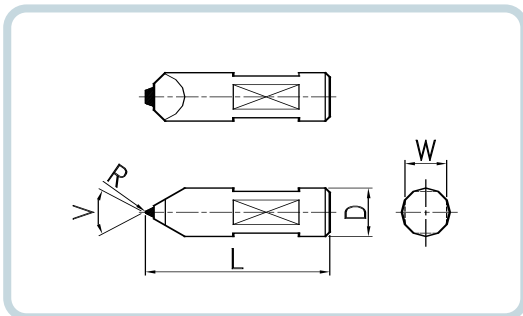

	D	L	w	V	R
Standard	11	45	9	55	0.2

● FDD-D14 ●

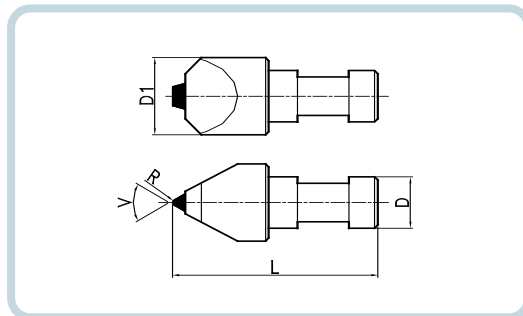

	D1	D	L	V	R
Standard	12	8	32	55	0.2

● FDD-D17 ●

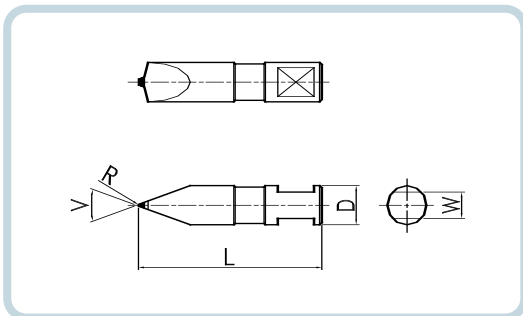

	D	L	W	V	R
Standard	9.5	44.5	6	40	0.25

● FDD-D19 ●

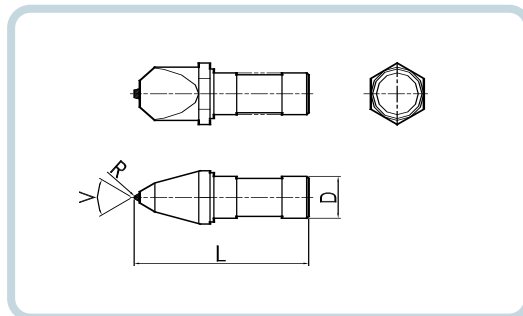

	D	L	V	R
Standard	11	46	60	0.3

● FDD-D20 ●

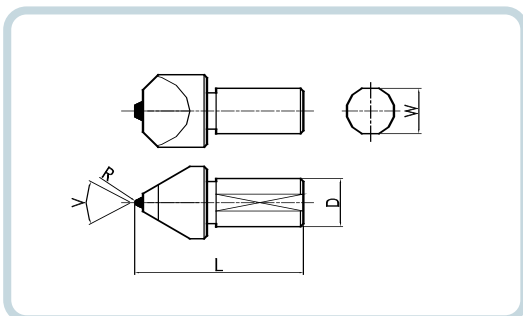

	D	L	V	R
Standard	8	29	55	0.2

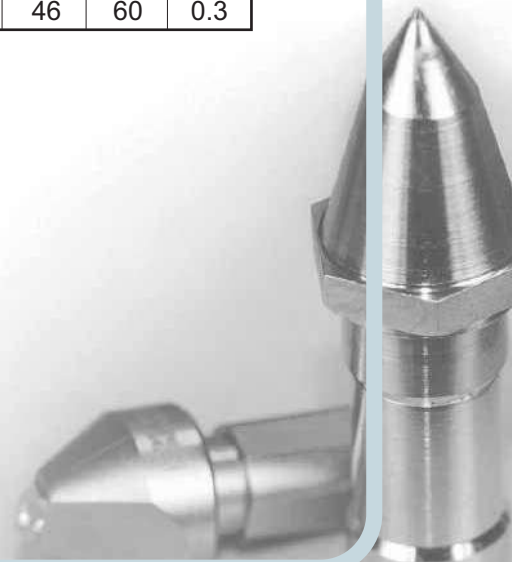

# DIAMOND DRESSER

# MDD

Multi-point  
Diamond Dresser



## Multi Diamond Dressers :

Two or more selected diamonds are set in a metal matrix to provide multi diamond points for dressing larger and wider conventional abrasive wheels. Multi-point diamond dressers have two types. One is a general type for dressing straight type conventional abrasive wheels; the other a blade type for dressing larger and conventional abrasive profile wheels at lower cost.

Multi-point diamond dressers using diamonds made by chemical vapor deposition are suited to get high quality surface finish and consistent performance. On the other hand, multi-point diamond dressers made of elongated natural diamonds, which is called "Fliesen tool", have longer tool life.





## Natural



Available diamond :  
A ( Octahedron ),  
B ( Dodecahedron )

Available carat :  
Max 1/3 ct ~ Min 1/30 ct

## Blade type

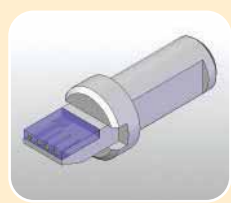
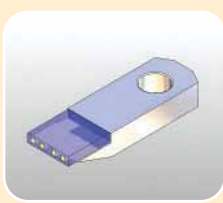

Available size :  
CVD 0.4 mm X 0.4 mm X 5 mm  
CVD 0.6 mm X 0.6 mm X 5 mm  
CVD 0.8 mm X 0.8 mm x 3 mm  
CVD 0.8 mm X 0.8 mm X 6 mm  
CVD 1.0 mm X 1.0 mm X 3 mm  
Elongated 1/20 ct ~ 1/80 ct

## Specifications

### ● MDD-A01 ●

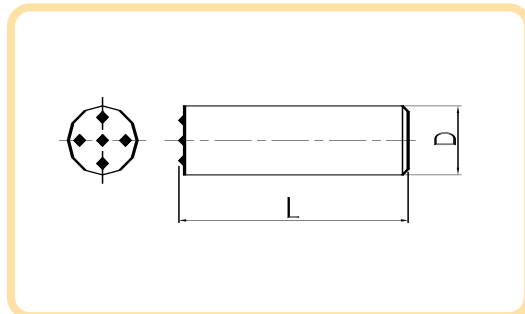

	D	L
Standard	11	40

### ● MDD-A05 ●

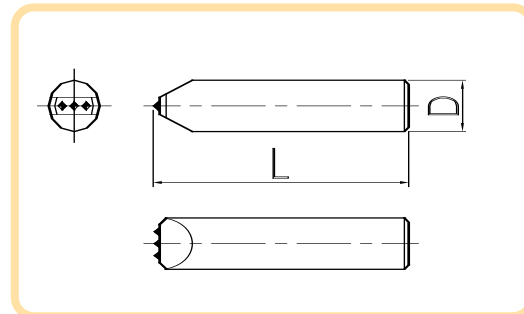

	D	L
Standard	11	40

### ● MDD-A09 ●

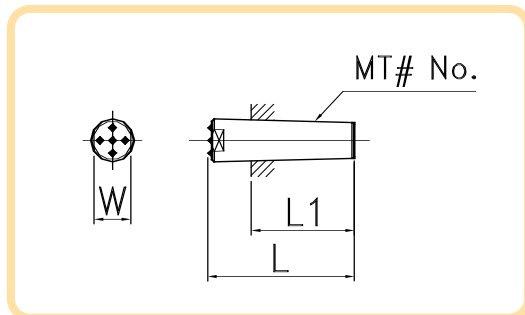

	L	L1	W	Taper
Standard	32	22	8	MT#No.1

### ● MDD-A10 ●

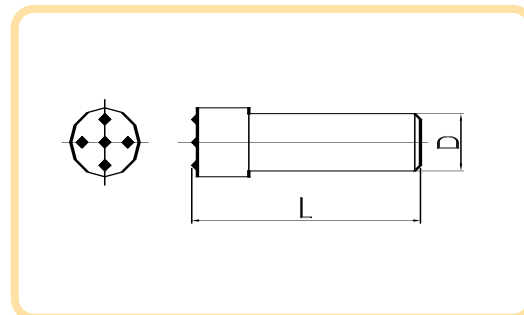

	D	L
Standard	11	29

# Specifications

● MDD-G11 ●

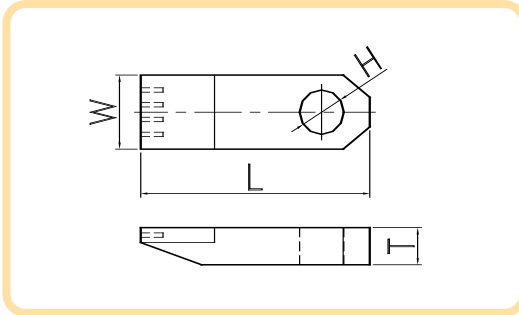

	L	T	W	H
Standard	28	5	10	6.1

● MDD-G12 ●

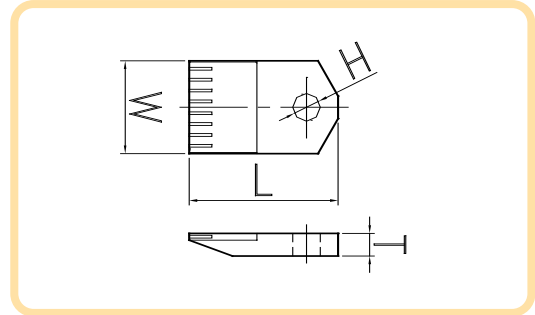

	L	T	W	H
Standard	33	5	20	6.1

● MDD-G13 ●

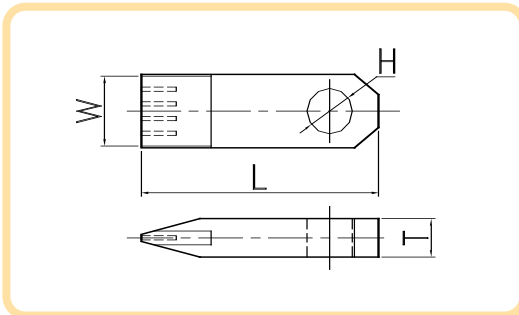

	L	T	W	H
Standard	28	5	10	6.1

● MDD-G14 ●

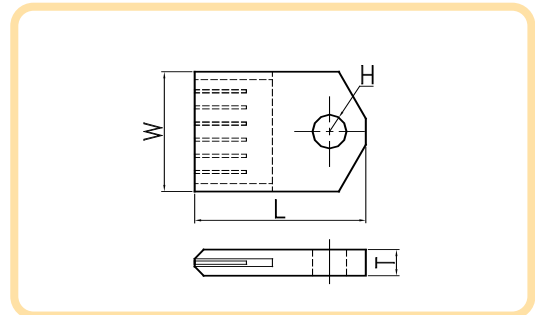

	L	T	W	H
Standard	33	5	20	6.1

● MDD-G21 ●

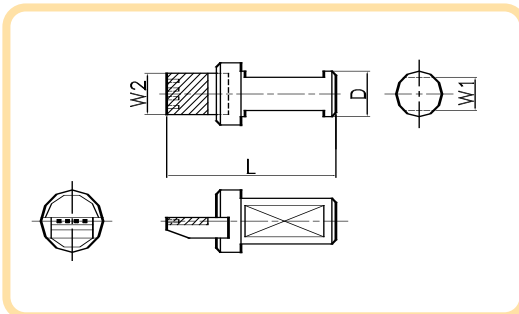

	D	L	W1	W2
Standard	11	41	8	10

● MDD-G22 ●

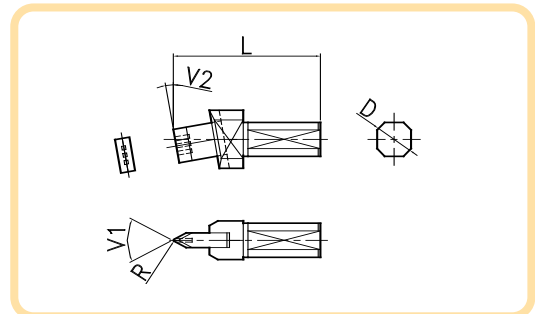

	D	L	V1	V2	R
Standard	8	29	55	10	0.3



● MDD-G23 ●

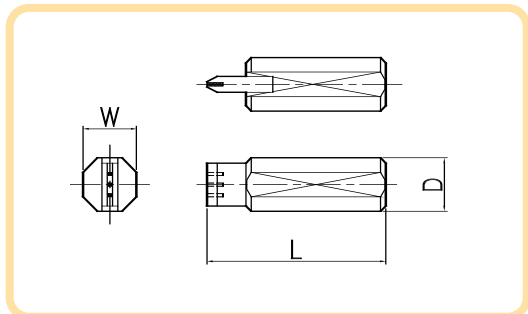

	D	L	W
Standard	11	33	10

● MDD-G24 ●

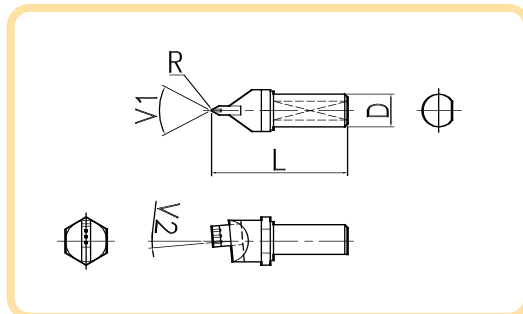

	D	L	V1	V2	R
Standard	11	46	55	5	0.3

● MDD-C12 ●

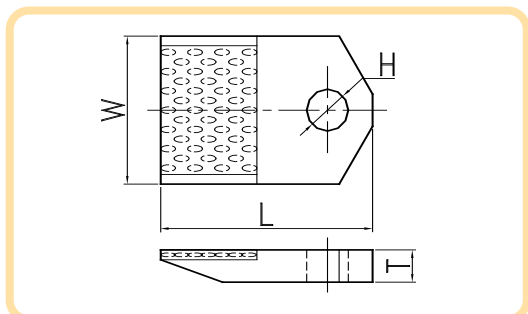

	L	T	W	H
Standard	28	5	20	6.1

● MDD-C14 ●

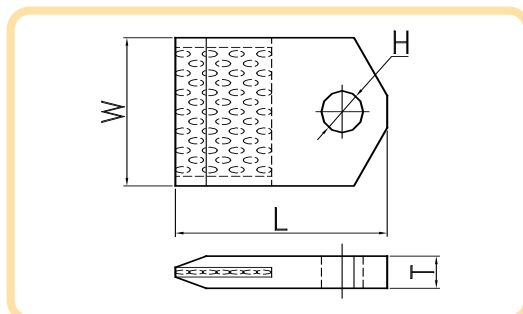

	L	T	W	H
Standard	33	5	20	6.1

● MDD-B13 ●

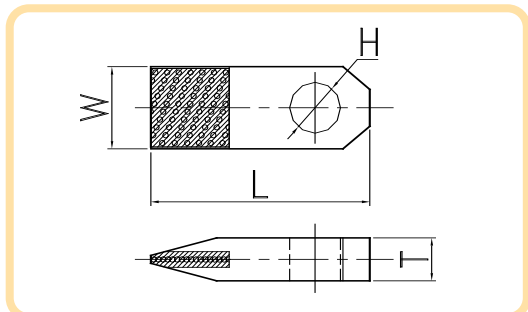

	L	T	W	H
Standard	28	5	10	10

● MDD-B12 ●

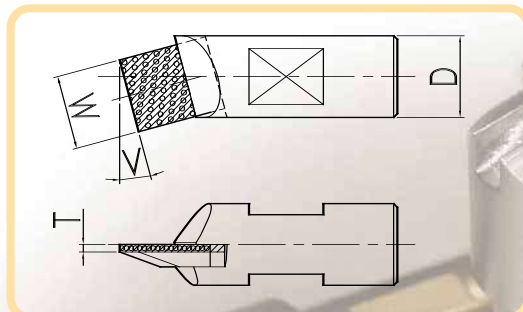

	D	W	V	T
Standard	8	10	15	1.5

# DIAMOND DRESSER

## IDD

Impregnated  
Diamond Dresser

### DIPROTEX® TECHNOLOGY

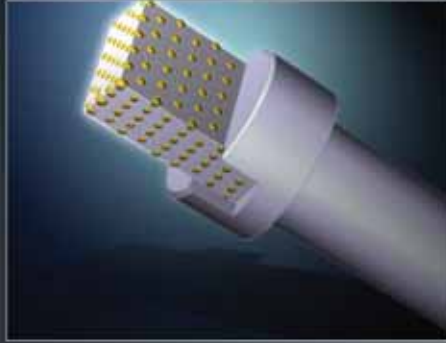

### Impregnated Diamond Dressers :

Impregnated diamond dressers have tiny diamond particles bonded in metal matrix. Dressing force is spread across the fine diamonds; impregnated diamond dressers can achieve longer tool life at lower cost.

Randomly distributed impregnated diamond dressers cannot optimally show their performance as required. That is why Diprotex has developed patterned impregnated diamond dressers manufactured with **DIPROTEX®** technology for dressing with precision.

### DIPROTEX® IDD

(Patterned Impregnated Diamond Dresser)  
Patent no. 10-0428947 / US 6626167

- Suitable for longer tool life and better performance
- Available mesh : # 20 ~ # 60



### Impregnated Diamond Dresser

- Used for economical dressing
- Available mesh : #20 ~#140





# Specifications

● IDD-S01 ●

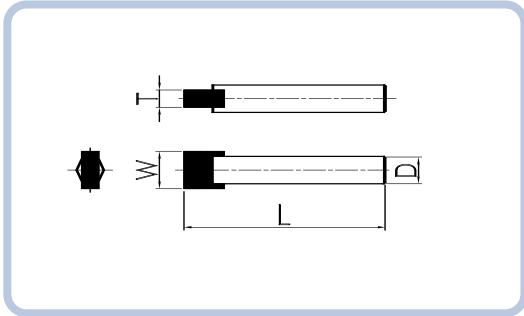

	D	L	W	T
Standard	11	70	13	6

● IDD-S03 ●

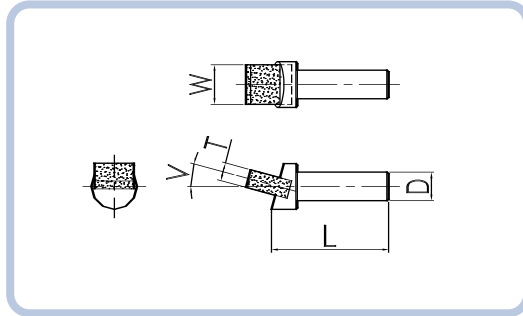

	D	L	W	T	V
Standard	11	38	13	6	15

● IDD-S04 ●

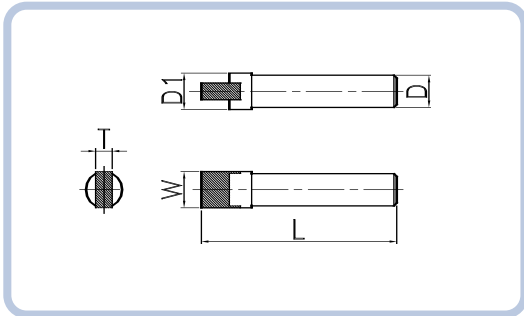

	D	D1	L	W	T
Standard	11	14	70	13	6

● IDD-S05 ●

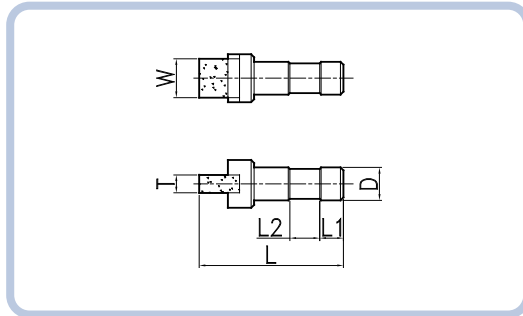

	D	L	L1	L2	W	T
Standard	11	50	7	10	13	6

● IDD-R01 ●

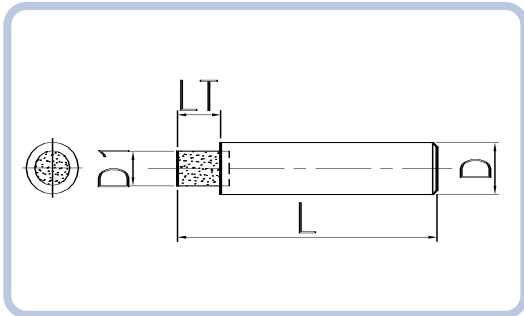

	D	D1	L	LT
Standard	11	9	40	8

● IDD-R03 ●

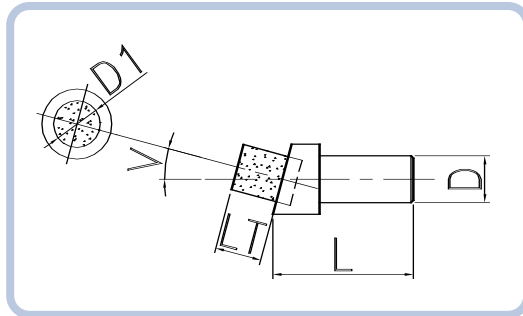

	D	D1	L	LT	V
Standard	11	9	38	8	15

● IDD-R04 ●

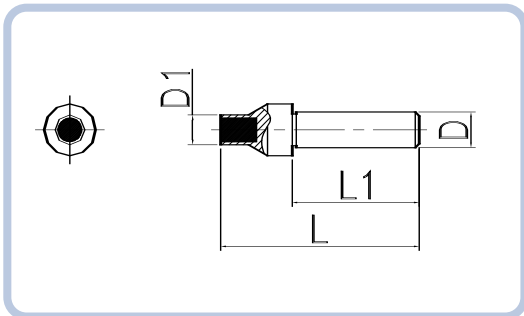

	D	D1	L	L1
Standard	11	10	40	24

● IDD-R05 ●

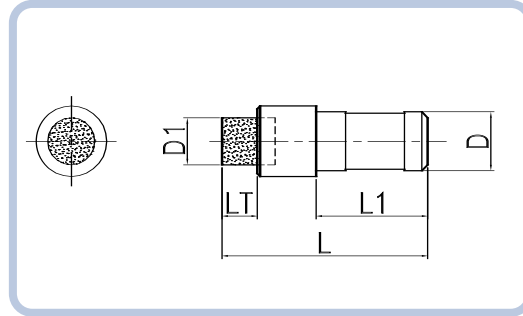

	D	D1	L	L1	LT
Standard	11	9	40	24	8

## Burnishing tools

Burnishing tools are manufactured by natural or mono crystalline diamonds. The burnishing process is a cold process using proper pressure without removal of the work pieces. The burnishing tools are very useful for metalworking because they help get high quality mirror-like surface finish and meet dimensions as requested. The diamond burnishing tools can ensure longer tool life and good surface finish.

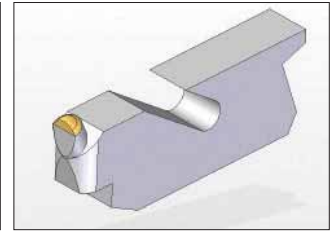
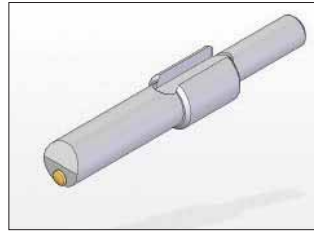

## PCD (Poly-crystalline diamond) dressers

PCD dressers are cost-effective alternative in dressing conventional abrasive profile wheels. The PCD is easier to get desired shapes than the other diamond materials. As a result, PCD dressers can dress grinding wheels with complex profiles. The relatively lower tool life can be compensated by lower price.

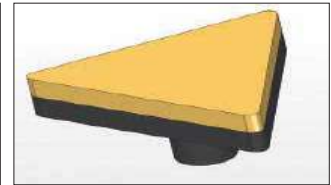
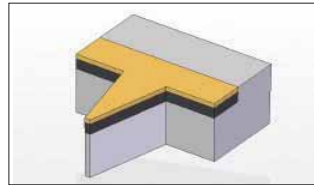
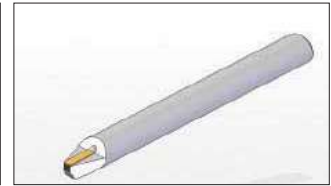

## Contact gauges

Contact gauges with natural diamonds or poly-crystalline diamonds have almost 100 times longer tool life than tungsten carbides or high-speed steel. The diamond contact gauges can ensure highly accurate measurement with ultra wear resistance.

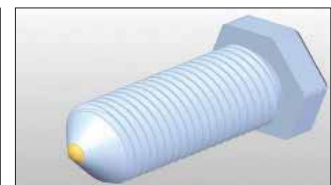
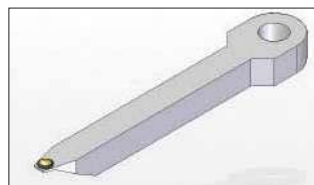
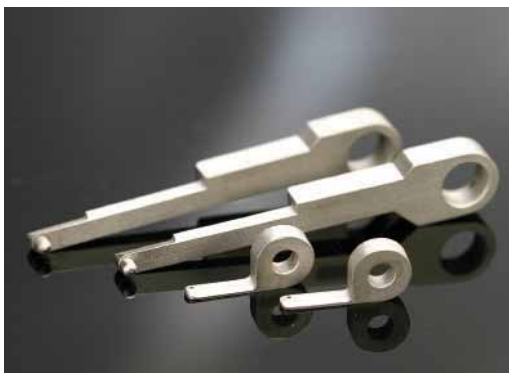





DIAMOND DRESSERS